

Sea Pro® FH240 Series Filter/Separator Installation Instructions

Sea Pro® Single Short

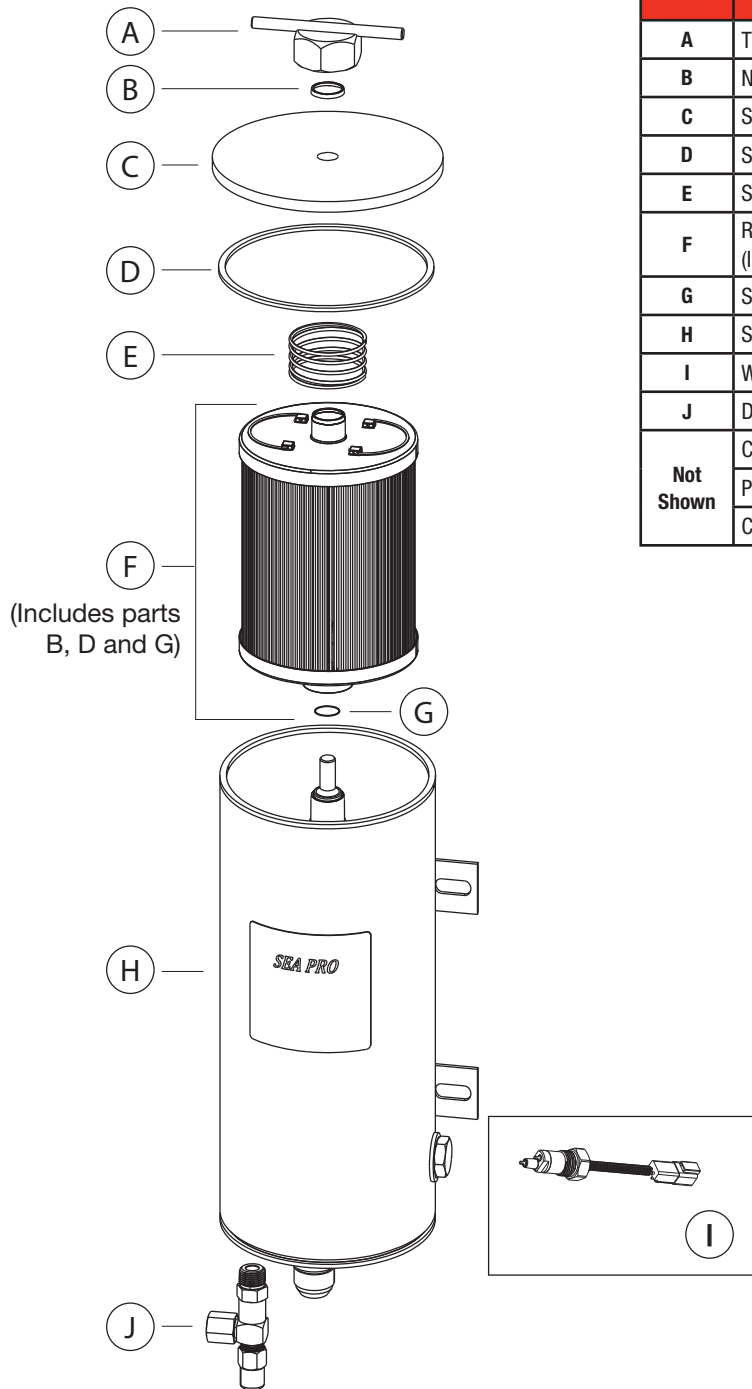

Part	Description	Part Number
A	Top Nut Handle	SP1288
B	Nut Seal	SP1287
C	Service Cap	SP1286
D	Service Cap Seal	SP1285
E	Spring	SP1284
F	Replacement Element and Seals (Includes parts B, D, and G)	FS53021
G	Stand Pipe Gasket	SP1283
H	Sea Pro FH240 Single Short	See page 8
I	WIF Sensor (optional)	SP1428
J	Drain Valve	SP1289
Not Shown	Compound Pressure Gauge	SP1639
	Priming Pump Kit	3961294 S
	Check Valve	3961295 S

⚠ CAUTION: These instructions are intended for use by professional mechanics who are trained in the proper use of power and hand tools, using appropriate safety precautions (including eye protection).

Sea Pro® Duplex Short

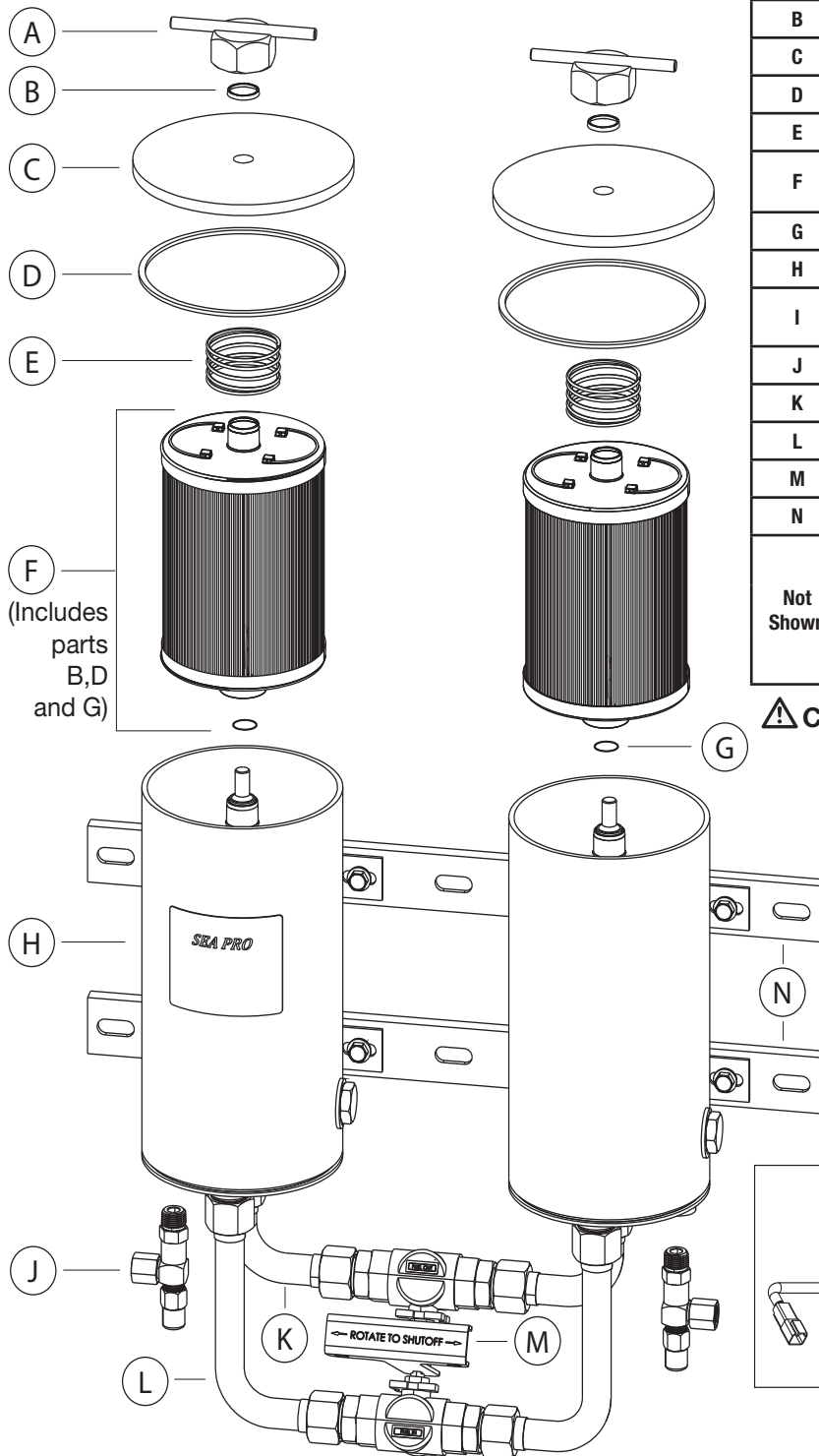

Part	Description	Part Number
A	Top Nut Handle	SP1288
B	Nut Seal	SP1287
C	Service Cap	SP1286
D	Service Cap Seal	SP1285
E	Spring	SP1284
F	Replacement Element and Seals (Includes parts B, D, and G)	FS53021
G	Stand Pipe Gasket	SP1283
H	Sea Pro FH240 Duplex Short	See page 8
I	WIF Sensor Kit (optional) WIF Sensor	SP1433 SP1641
J	Drain Valve	SP1289
K	Fuel Out Manifold Kit	SP1296
L	Fuel In Manifold Kit	SP1297
M	Handle	SP1293
N	Bracket (two included in kit)	SP1298
Not Shown	Compound Pressure Gauge	SP1531
	Priming Pump Kit	3961294 S
	Check Valve	3961295 S

⚠ Caution: Do not attempt to remove or relocate manifolding on duplex units. Doing so will void the warranty.

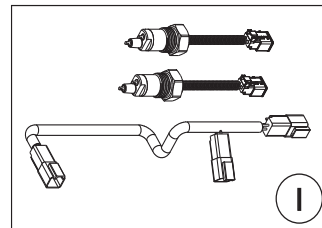

Sea Pro® Single Tall

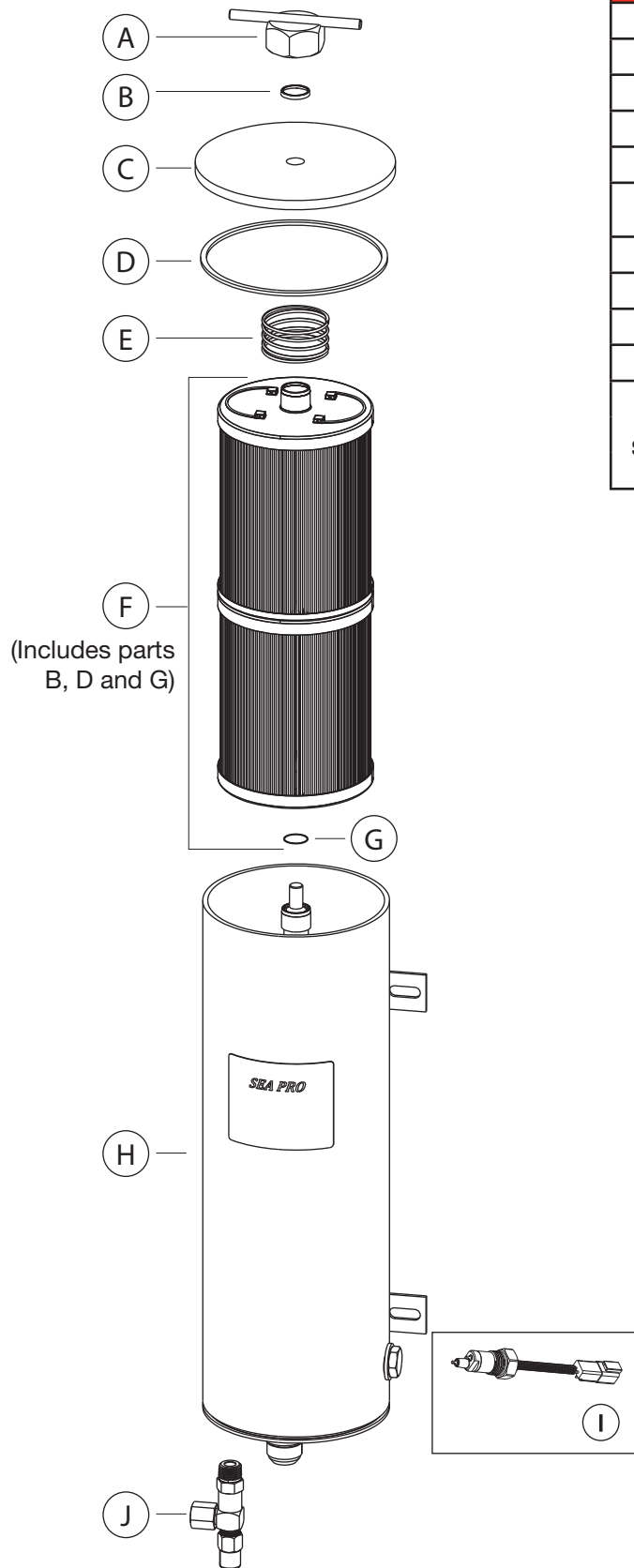

Part	Description	Part Number
A	Top Nut Handle	SP1288
B	Nut Seal	SP1287
C	Service Cap	SP1286
D	Service Cap Seal	SP1285
E	Spring	SP1284
F	Replacement Element and Seals (Includes parts B, D, and G)	FS53022
G	Stand Pipe Gasket	SP1283
H	Sea Pro FH240 Single Tall	See page 8
I	WIF Sensor (optional)	SP1428
J	Drain Valve	SP1289
Not Shown	Compound Pressure Gauge	SP1639
	Priming Pump Kit	3961294 S
	Check Valve	3961295 S

Sea Pro® Duplex Tall

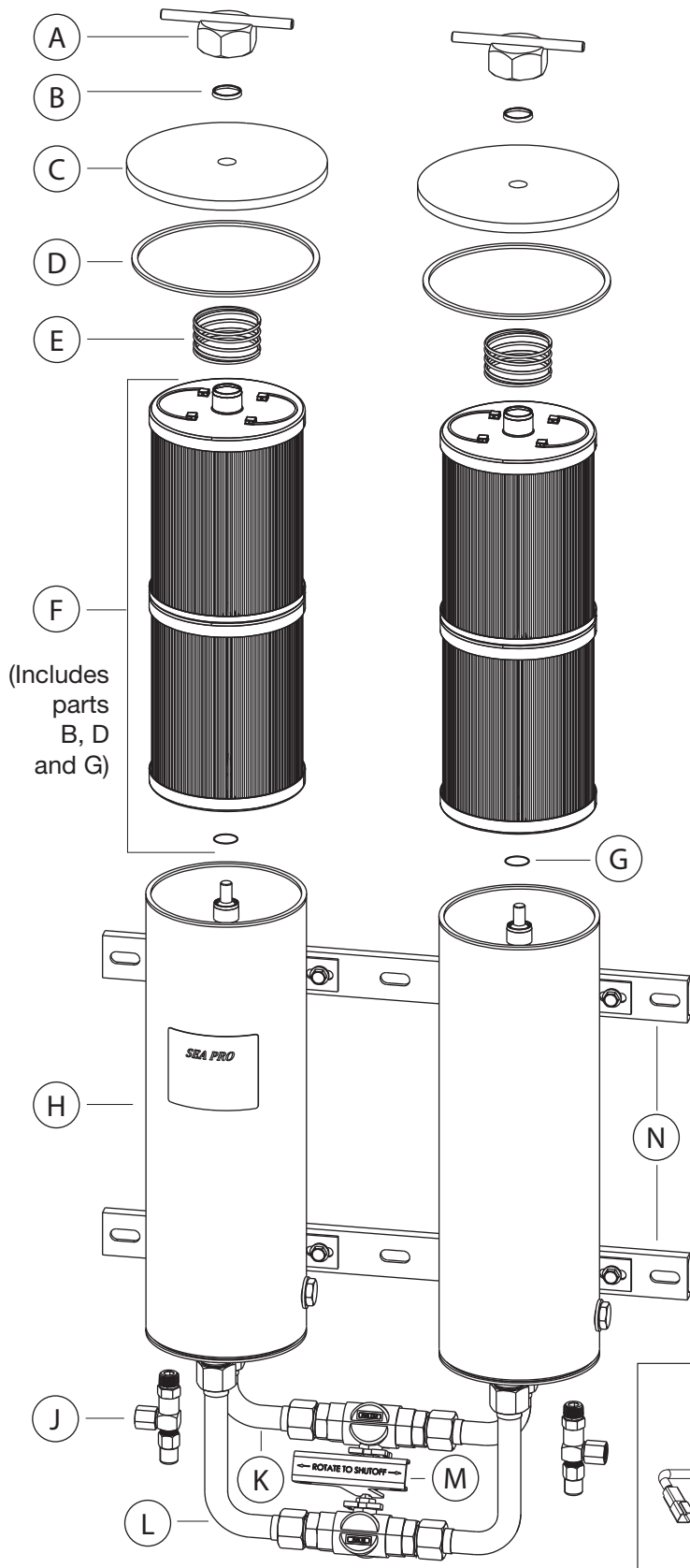

Part	Description	Part Number
A	Top Nut Handle	SP1288
B	Nut Seal	SP1287
C	Service Cap	SP1286
D	Service Cap Seal	SP1285
E	Spring	SP1284
F	Replacement Element and Seals (Includes parts B, D, and G)	FS53022
G	Stand Pipe Gasket	SP1283
H	Sea Pro FH240 Duplex Tall	See page 8
I	WIF Sensor Kit (optional) WIF Sensor	SP1433 SP1641
J	Drain Valve	SP1289
K	Fuel Out Manifold Kit	SP1296
L	Fuel In Manifold Kit	SP1297
M	Handle	SP1293
N	Bracket (two included in kit)	SP1298
Not Shown	Compound Pressure Gauge	SP1531
	Priming Pump Kit	3961294 S
	Check Valve	3961295 S

⚠ Caution: Do not attempt to remove or relocate manifolding on duplex units. Doing so will void the warranty.

Fuel Processor Installation

This system must be installed between the fuel tank and the transfer fuel pump on the suction side of the fuel system.

⚠ WARNING: When diesel fuel is circulated through an operating engine, it can become very hot. To prevent personal injury:

⚠ Scalding hazard! Do not allow heated liquid fuel to come in contact with eyes or unprotected skin. Always allow the engine and fuel to cool to ambient temperature before replacing the fuel filter or performing service operations which could result in the spillage of fuel from the fuel system. If this is not possible, protective clothing (face shield, insulated hat, gloves, apron) must be worn.

⚠ Heated diesel fuel can form combustible vapor mixtures in the area around the fuel source. To eliminate the potential for fire, keep open flames, sparks or other potential ignition sources away from the work area, and do not smoke during filter replacement or service operations which could result in the escape of diesel fuel or fuel vapors.

⚠ Always perform engine or vessel fuel system maintenance in a well ventilated area that is kept free of bystanders.

Installation Steps

1. With the engine shut down and at ambient temperature, close the fuel shutoff valve (if equipped) and place a suitable container under the fuel filters.
2. Remove the primary fuel filter element assembly, sedimenter, and/or water separator. Drain the used element and dispose of it in an environmentally responsible manner, according to state and/or federal (EPA) recommendations. The fuel can be returned to the tank.

Installation of the Sea Pro must be on the suction side of the fuel system. Do not exceed 2.2 lb/in² (15 kPa) inlet pressure to the fuel processor.

3. Mount the Sea Pro® in the desired location keeping the following points in mind:
 - a. **DO NOT mount the Sea Pro directly on the engine.**
 - b. Mount vertically with the service cap towards the top.
 - c. Make sure there is enough top and side clearance for the cover to be conveniently removed for filter replacement.
 - d. Make sure the filter service clearance meets these requirements:
Sea Pro Short,
Single and Duplex: 10.6" (269.2 mm)
Sea Pro Tall,
Single and Duplex: 18.3" (464.8 mm)
4. Route the fuel supply line from the fuel tank to the Sea Pro inlet (see Figure 1). Route a fuel line from the Sea Pro outlet to the fuel pump inlet.

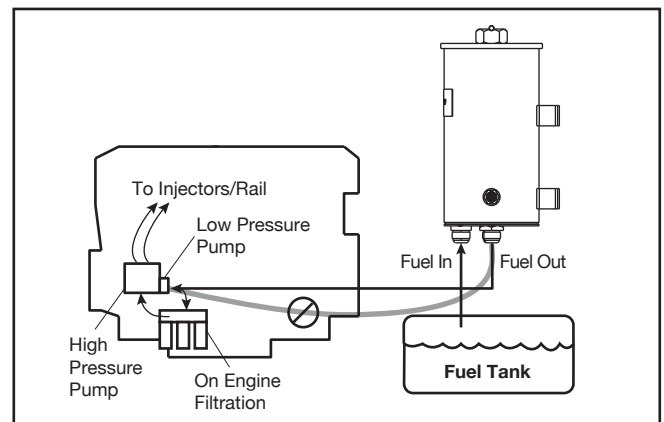

Figure 1 - Sea Pro Connections

⚠ CAUTION: To avoid fuel line water traps that can freeze in cold conditions and restrict, or block, the flow of fuel to the engine, be certain that there are no low spots in the hoses when routing them in the engine compartment.

5. To minimize restrictions, observe the following guidelines when plumbing the system.
 - a. Keep the fuel line routing as smooth as possible with no low hanging loops which can trap water.
 - b. Use 90° elbows only when necessary.

- c. If the fuel hoses are made up to length on the job, be sure that the inner liner of the fuel hose is not cut by the fitting, creating potential check valve effects. Also make sure hoses are clean and free of debris before installing.

⚠ CAUTION: To avoid damaging the steel fuel housing, do not overtighten fuel lines or fuel line fittings.

6. Apply marine grade anti-seize to the inlet and outlet hose threads and connect the hoses to the unit.

Installing an Optional WIF (Water In Fuel) Sensor

Install the WIF Probe (SP1428) into the side of the Sea Pro®. (See Figure 2, which references a single unit. For a duplex unit, use WIF Probe SP1641 and follow the same procedure.)

1. Remove WIF plug.
2. Install the adapter into the WIF plug port.
3. Torque to 25-40 ft-lbs (33.9-54.2 N·m).
4. Install WIF sensor into the adapter.
5. Torque to 25-40 in-lbs (2.82-4.52 N·m). (See Figure 2)

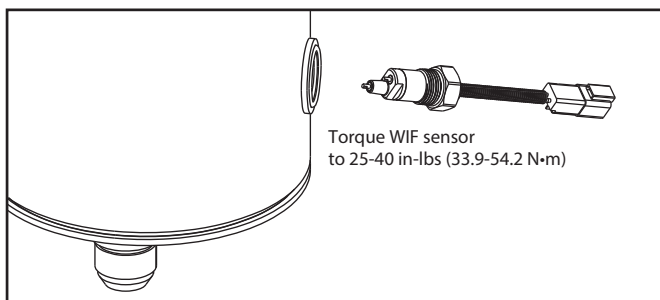

Figure 2 - WIF Probe Installation

Installing an Optional WIF Indicator LED Light

1. Drill 1/2" (12.70 mm) hole in the control panel where the WIF LED (3946670 S) is to be located.
 - a. Installation must have 1.5" (38.10 mm) of clearance behind dash or control panel.
 - b. Use caution not to damage nearby components when drilling.

2. Install WIF LED by pressing firmly into the drilled hole.
3. Connect the 4" (101.60 mm) black ground wire on WIF LED to a ground source. Attach additional black wire as needed.
4. Connect the 12" (304.8 mm) black ground lead with a 3/8" (9.53 mm) diameter loop end on the WIF wiring harness to ground source near Fuel Processor (if applicable).
5. Connect 72" (1828.80 mm) green signal wire on WIF wiring harness to 4" (101.60 mm) green signal wire on WIF LED. Use additional green wire as needed.
6. Locate 12 VDC or 24 VDC power source. Run red wire from power source to 4" (101.60 mm) red wire on WIF LED. Add a 1 A in-line fuse (not included). (See Figure 3.)

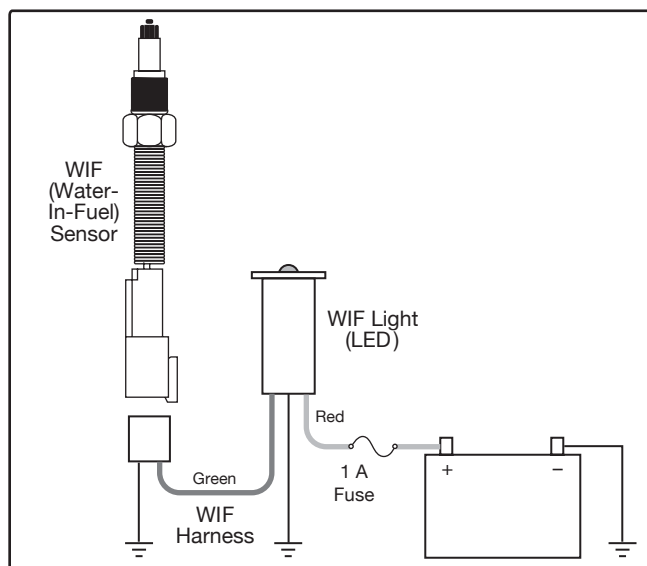

Figure 3 - WIF Wiring

Note: Use appropriate connectors to attach the wires. To test the WIF indicator, pour water into the body of the fuel processor until it covers the WIF probe. The WIF LED should illuminate. For the Duplex unit, purchase the WIF kit (SP1299) and one of the mentioned WIF LED kits and follow the same instructions.

Filter Change Procedure

1. Turn off the engine.
2. Shut off the fuel supply to the unit you are working on.
3. Remove Topnut handle and drain the fuel from the fuel processor.
4. Remove the service cap.
5. Remove the filter. Remove the seals from the service cap and standpipe. Dispose of the filter and the seals properly.
6. Using a clean shop rag, clean the service cap and seal grooves.
7. Install the new filter (make sure to align the engine integrated protection (EIP) feature) and the seals (included with the replacement filter).

Table 3 – Sea Pro Replacement Filters

Part Number	Description
FS53021	NanoNet™ 5 micron (short)
FS53022	NanoNet 5 micron (tall)

8. Place the service cap back on the housing, ensuring the cap is centered on the housing. Install the Topnut handle and hand tighten.
9. Prime the fuel system using the electric priming pump.

Valve Operation

1. For single unit flow, rotate the valve handle either to left or right depending on which unit is to be used. (Rotate the handle either left or right) See Figure 4.
2. For duel unit flow, rotate the valve handle 180° from the shutoff position. (Rotate the handle to the front) See Figure 4.
3. To shut off flow, rotate the valve handle 180° from the duel flow position. (Rotate the handle to the back) See Figure 4.

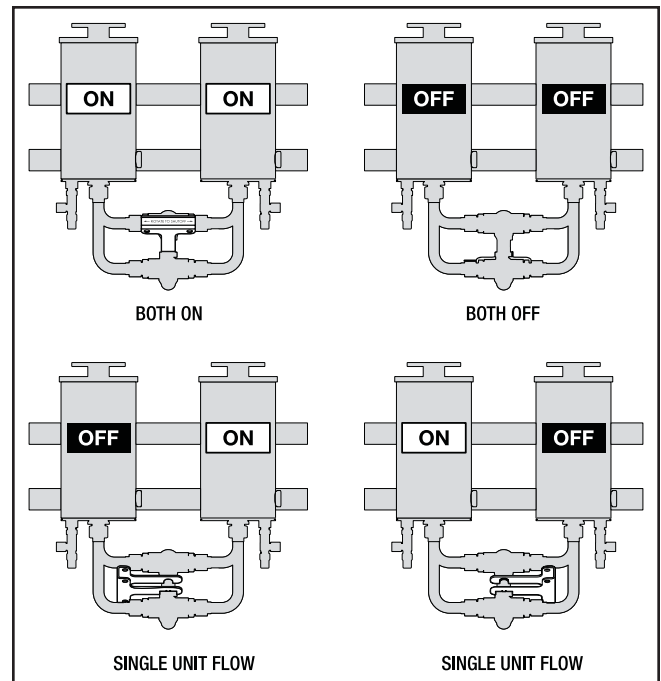

Figure 4 - Valve Operation

Draining Contaminants

1. Turn off the engine and remove the service cap and top nut handle.
2. Place a container under the drain valve at the base of the Sea Pro and open the drain valve.
3. Water will flow into the container. When fuel begins to flow out of the drain, close the drain valve. (Drain the minimum amount of fuel possible.)
4. Reinstall the top nut handle and hand tighten.
5. Start the engine. Raise the RPM for one minute to purge the air from the system.

Suggested Preventive Maintenance

Sea Pro:

Weekly – Drain water.

Every Filter Change – Change o-rings and seals.

Every 12 Months – Check all electrical connections for corrosion. Check all fuel fittings for leaks.

Sea Pro® Ordering Information

Housing Part Number	Filter Element	Unit Type	WIF	Drain	Bracket Included	Fuel In and Fuel Out	Port Size
FH24000	FS53021	Single Short	Yes*	Yes	No	Bottom In / Bottom Out	1-5/16"-12 UN/UNF-2A 37° Flare
FH24001	FS53022	Single Tall	Yes*	Yes	No	Bottom In / Bottom Out	1-5/16"-12 UN/UNF-2A 37° Flare
FH24002	FS53021	Duplex Short	Yes**	Yes	Yes	Bottom In / Top Out	1-5/16"-12 UN/UNF-2A 37° Flare
FH24003	FS53022	Duplex Tall	Yes**	Yes	Yes	Bottom In / Top Out	1-5/16"-12 UN/UNF-2A 37° Flare

* WIF Kit part number **SP1428**

** WIF Kit part number **SP1641**

Torque Values

Application	Torque		
	in-lb	ft-lb	Nm
WIF Probe	25-40	2.08-3.33	2.82-4.52
WIF Adapter to Housing	300-480	25-40	33.9 - 54.2
Drain Valve to Housing	180 min - rotate to position	15 min - rotate to position	20 min - rotate to position
Fuel Line In	1380 - 1620	115 - 135	155.9 - 183
Fuel Line Out	1380 - 1620	115 - 135	155.9 - 183

Sea Pro® Specifications

Specification	Single Short	Single Tall	Duplex Short	Duplex Tall
Height Overall	19.2" (488 mm)	26.70" (678 mm)	24.90" (632.50 mm)	32.40" (823.0 mm)
Depth Overall	8.75" (222 mm)	8.75" (222 mm)	11.1" (282 mm)	11.1" (282 mm)
Width, max	8.2" (208 mm)	8.2" (208 mm)	26.00" (660 mm)	26.00" (660 mm)
Weight (Dry)	31 lbs (14.1 kg)	43 lbs (19.5 kg)	80 lbs (36.3 kg)	103 lbs (46.7 kg)
Fuel Capacity (w/o filter)	1.2 gal (4.6 L)	2.5 gal (9.3 L)	2.4 gal (9.2 L)	4.9 gal (18.6 L)
Fuel Connections	1-5/16"-12 UN/UNF-2A	1-5/16"-12 UN/UNF-2A	1-5/16"-12 UN/UNF-2A	1-5/16"-12 UN/UNF-2A
Fuel Flow Rate	360 gal/hr (22.7 L/min)	540 gal/hr (34 L/min)	720 gal/hr (45.4 L/min)	1080 gal/hr (68 L/min)
Water Holding Capacity	66 fl oz (1970 ml)	66 fl oz (1970 ml)	132 fl oz (3940 ml)	132 fl oz (3940 ml)
Filter Service Clearance	Min. 10.6" (270 mm)	Min. 18.3" (465 mm)	Min. 10.6" (270 mm)	Min. 18.3" (465 mm)
Fuel Types				

Specifications subject to change without notice.

Dimensions

Sea Pro® Single Short

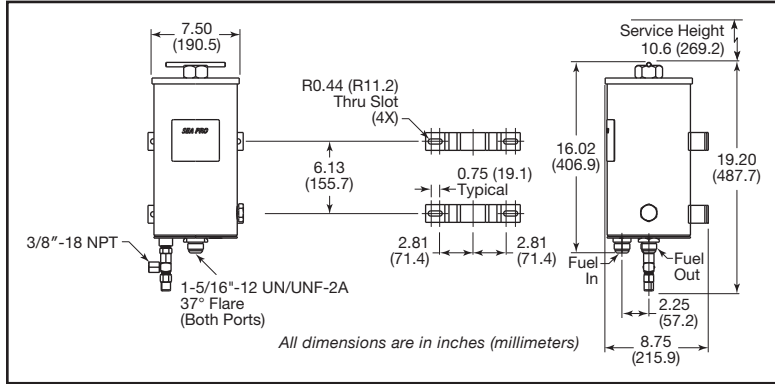

Sea Pro® Duplex Short

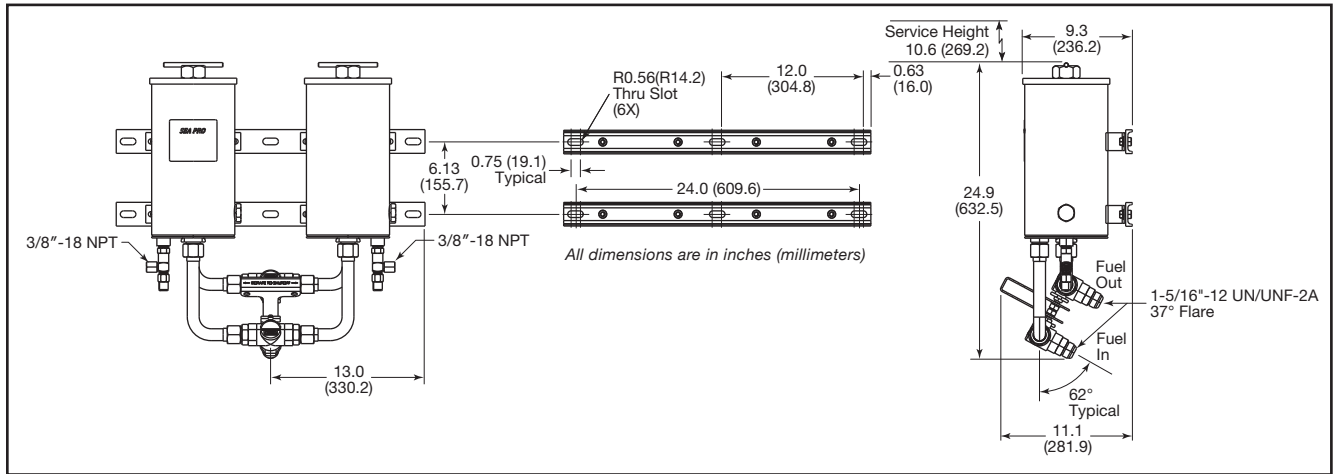

Sea Pro® Single Tall

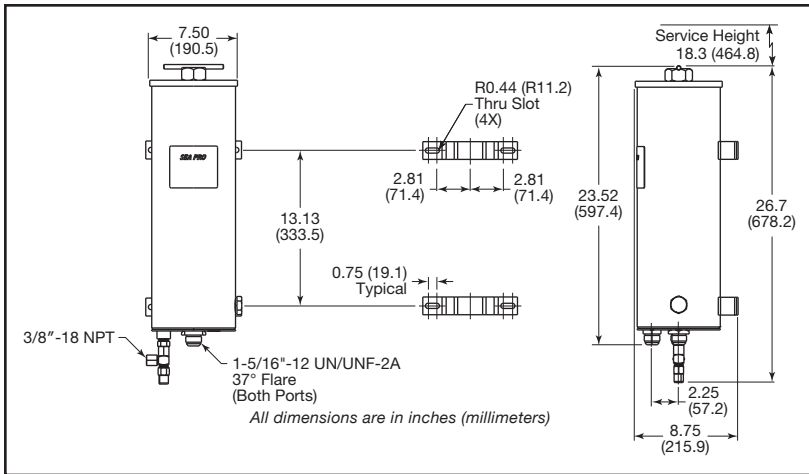

Sea Pro® Duplex Tall

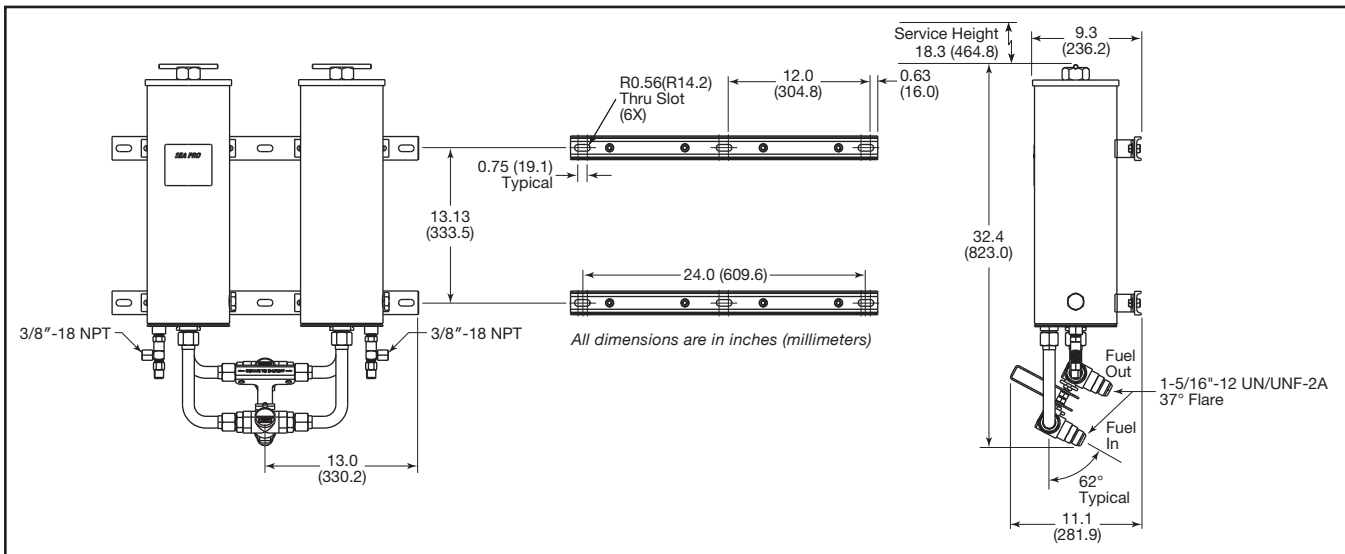

Filtration

For more information, visit cumminsfiltration.com

LT36370 Rev. A
 ©2018 Cummins Filtration Inc.
 Printed in the U.S.A.