

CUMMINS N14 ENGINE SERIES APPLICATIONS

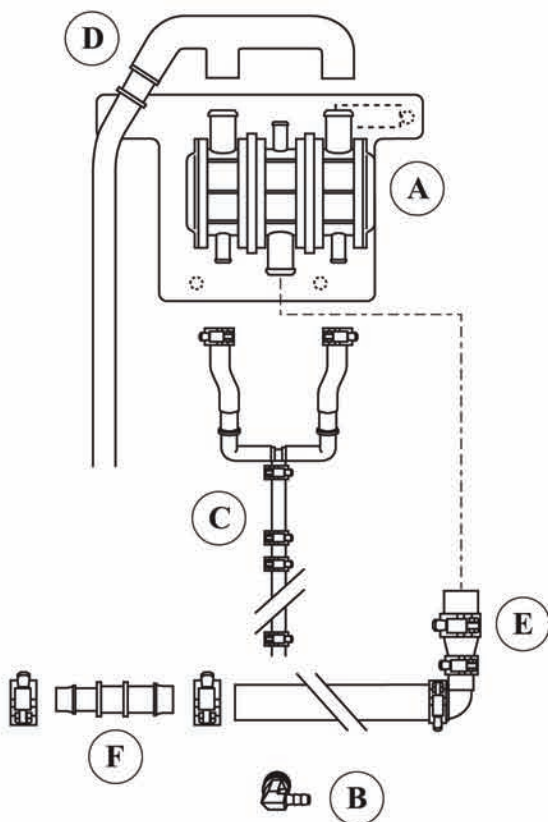

INSTALLATION INSTRUCTIONS

N14 Series Applications Crankcase Ventilation Kit #CV50201 Component Parts



- A. Breather and Bracket Assembly
- B. Drain Fitting
- C. Drain Hose Assembly
- D. Vent Hose Assembly
- E. Breather Inlet Hose Assembly
- F. Reducer Fitting and Clamps

CAUTION: These instructions are intended for use by professional mechanics who are trained in the proper use of power and hand tools, using appropriate safety precautions (including eye protection).

Installation Steps - N14 Series Engines

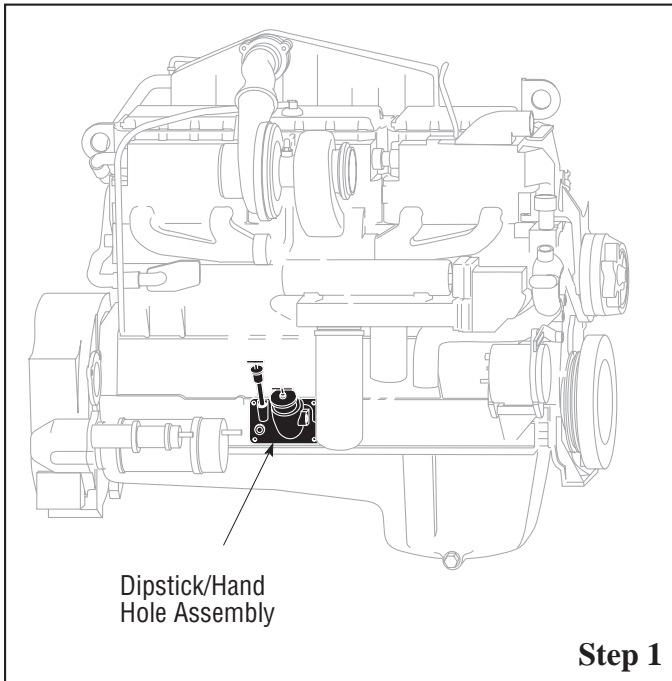

Locating and Mounting the Breather Assembly

Step 1 - Locate the dipstick/hand hole assembly positioned above the oil pan rail. Found on this assembly is up to three 1/2 inch NPT pipe plugs. Once an unused plug is located, determine the best location for mounting the breather assembly to ensure the drain hose will run directly to this hand hold assembly when installed. **The drain hose must be free of any loops, kinks or abrupt bends to ensure proper oil drainage.**

Note: On some engines, a 1/2 inch NPT pipe plug into the crankcase might not be available. In these cases, use best judgement for entering the crankcase by using adapter fittings.

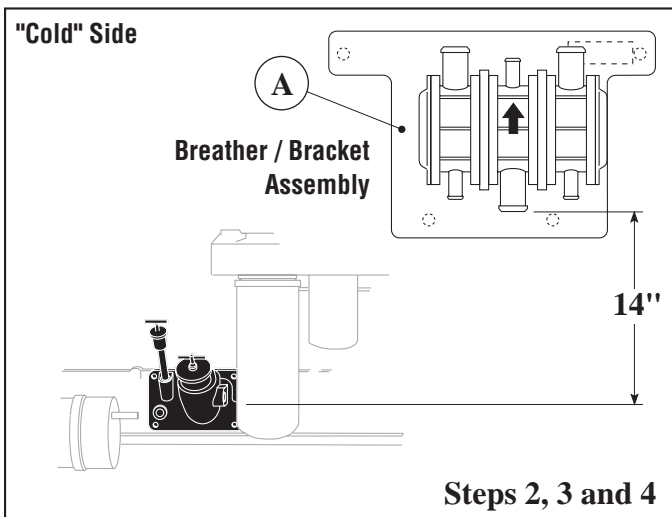

Step 2 - Find a mounting location for the breather assembly and bracket at least 14 inches (350 mm) above the drain port. The assembly must be a minimum of 4 inches (100 mm) from both the exhaust manifold and exhaust system components.

Step 3 - The "cold" side of the engine is the preferred location for mounting. The breather assembly must be mounted vertically (as shown) for proper operation.

Step 4 - Attach the bracket to the mounting location selected. When the bracket position has been determined, reverify the breather assembly is mounted vertically with the oil drain outlets directed downward.

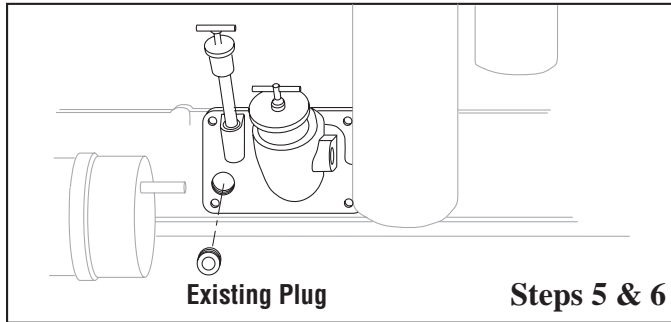

Installing the Drain Fitting Assembly

Step 5 - Locate the selected pipe plug in the dipstick hand hole assembly for removal.

Step 6 - Clean around the plug to ensure no dirt or contaminants will fall into the crankcase when the plug is removed. Loosen and remove the plug fitting. **Make sure no foreign materials enter the crankcase.**

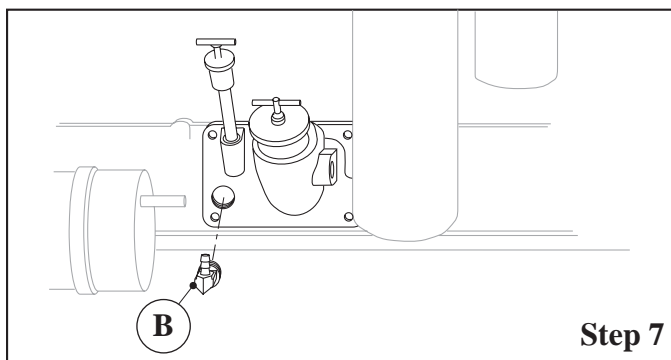

Step 7 - Screw in the drain fitting assembly and tighten until it is in the correct vertical orientation for easy drain hose routing. **Do not overtighten to obtain this orientation as destruction of the elbow will result.**

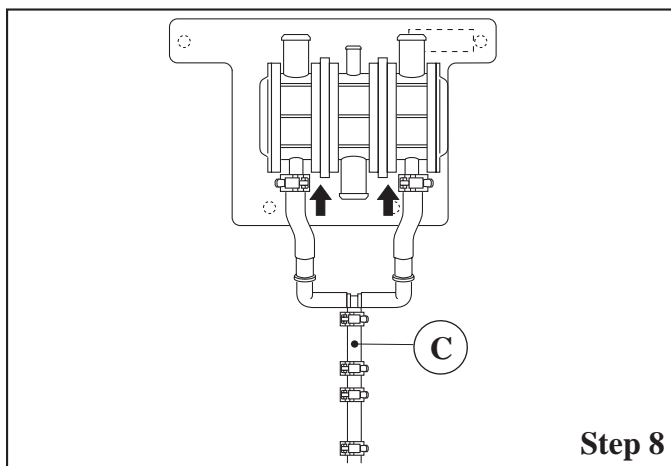

Installing the Drain Hose

The drain hose connects the breather assembly to the drain fitting assembly.

CAUTION: The drain hose must be free of any loops, kinks or abrupt bends to ensure proper oil drainage.

Step 8 - Attach the drain hoses to the breather assembly outlet tubes. Secure with clamps.

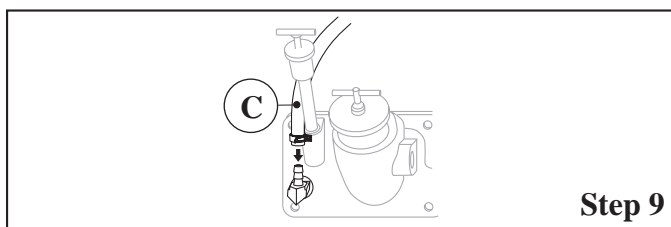

Step 9 - Route the drain hose to the drain fitting. **Ensure the check valve in the drain hose assembly is in a vertical position. If the hose is too long, trim the excess from the end of the drain hose. Do NOT cut off the check valve or any of the hose above the check valve. Secure with clamp. Reinspect the hose and routing to verify it is free of any loops, kinks or abrupt bends.**

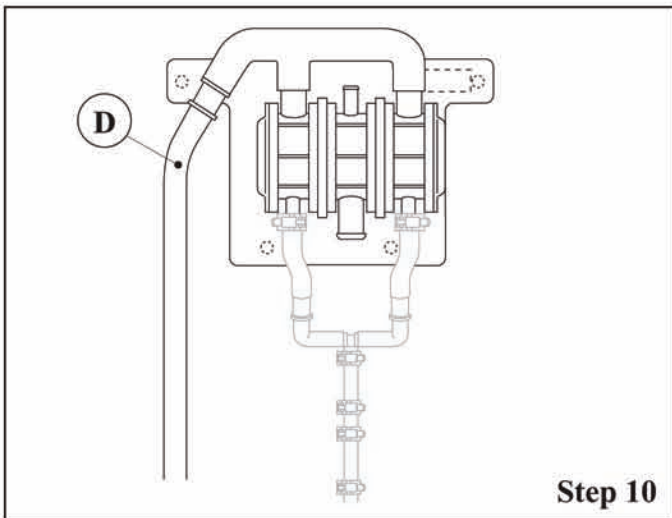

Step 10

Installing the Vent Hose Assembly

Step 10 - Attach the vent hose to breather assembly. Ensure the vent extension is directed downward and trim if necessary. Secure the loose hose to stabilize.

Step 11 (Optional) - If a longer vent extension hose is needed, attach a .75 inch (19 mm) ID hose (not included in the kit) to the vent extension using an appropriate connector. Stabilize the vent hose.

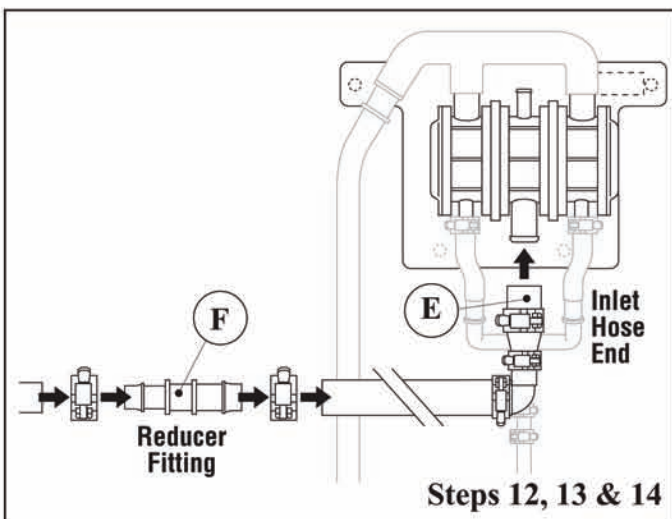

Steps 12, 13 & 14

Installing the Breather Inlet Hose Assembly

The final installation steps require routing the inlet hose from the breather assembly to the existing engine crankcase breather vent. This vent is located on the cold side of the engine's valve cover.

Step 12 - Secure the 1 inch (25 mm) ID inlet hose end to the breather assembly using the clamp provided.

Step 13 - Connect the 3/4 - 5/8 inch reducer fitting to the existing .625 inch (16 mm) ID engine breather vent hose. Secure with clamp.

Note: It may be necessary to remove the existing hose from its hold down in order to complete assembly.

Step 14 - Route the new inlet hose from the breather assembly to the adapter previously attached to the existing vent hose. Trim the .75 inch (19 mm) ID hose end to proper length and secure with clamp.

Note: To provide a better hose routing, it may be helpful to shorten the existing vent hose before connecting to the adapter.

CAUTION: Ensure the hose routing is a minimum of 4 inches (100 mm) from any hot surface. Avoid trimming too short to prevent hose kink after installation.



Filtration