

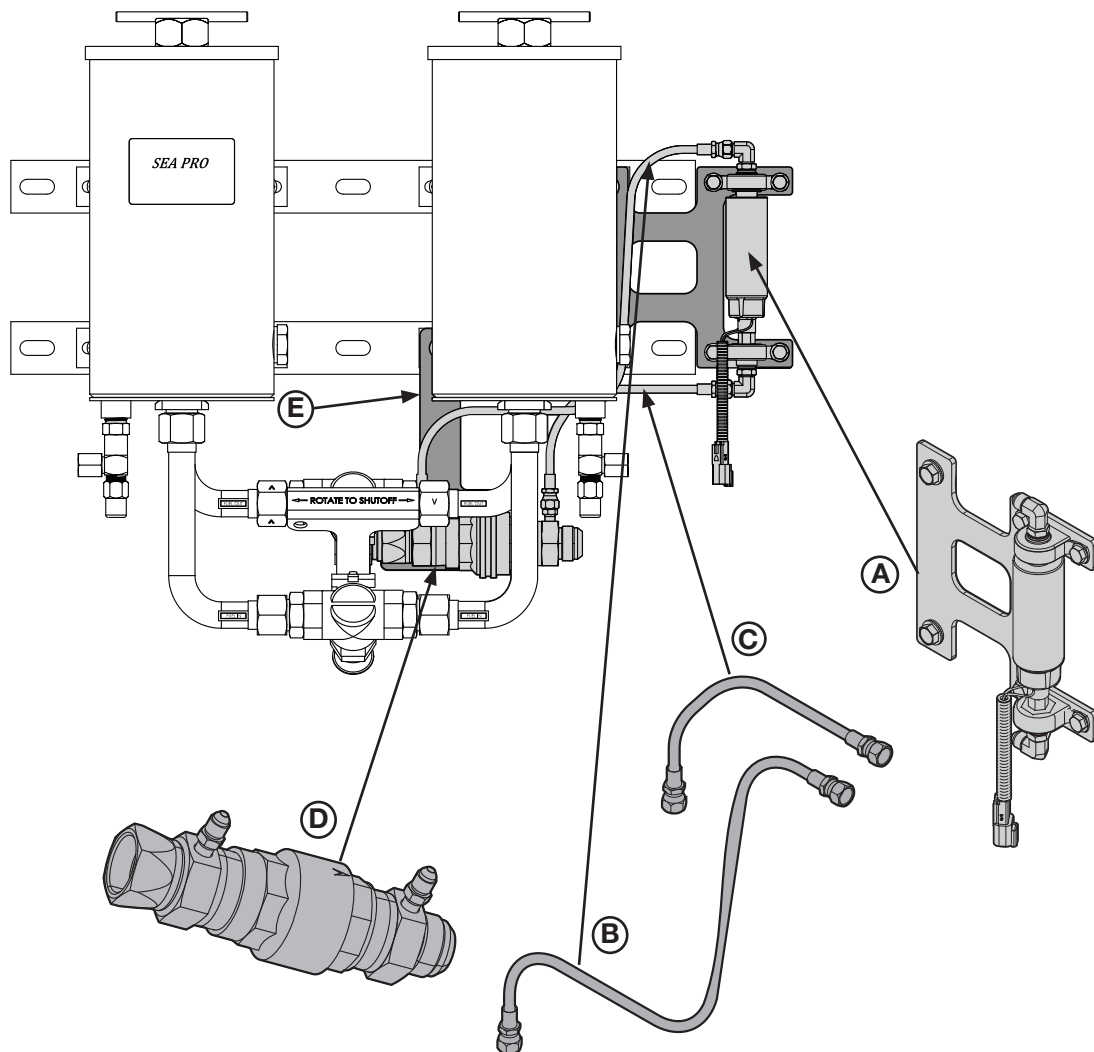

Primer Pump Assembly for FH240 Series Sea Pro[®] with Bypass Valve Installation Instructions

Primer Pump Assembly Kit

Part	Description	Part Number
A	Primer Pump Assembly	See Page 4 for Ordering Information
B	Inlet Hose	
C	Outlet Hose	
D	Primer Fitting Set (Bypass Valve)	
E	Bypass Valve Bracket	



⚠ CAUTION: These instructions are intended for use by professional mechanics who are trained in the proper use of power and hand tools, using appropriate safety precautions (including eye protection).

Introduction

The Fleetguard® Primer Pump Assembly can be mounted to the FH240 series Sea Pro fuel processor as an accessory service kit. It is bolted to the bracket of a Single (Short or Tall) or Duplex (Short or Tall) FH240 Sea Pro processor.

The Primer Pump kit should be mounted on the right side of the processor mounting bracket facing the outside and connected to the appropriate inlet/outlet fittings on the Bypass Valve with the provided hoses.

Please follow the same installation instructions when installing the Priming Pump kit w/o priming pump. You will be reusing the current priming pump on the legacy Sea Pro.

Installing the Primer Pump Kit

1. Mount the Primer Pump Assembly on the bracket of the Sea Pro unit. It should be bolted to the main bracket using the two 3/8" (9.5 mm) grade 8 short bolts provided, as shown in Figure 1. Torque to 15-30 ft-lb (20.4-40.7 N•m).

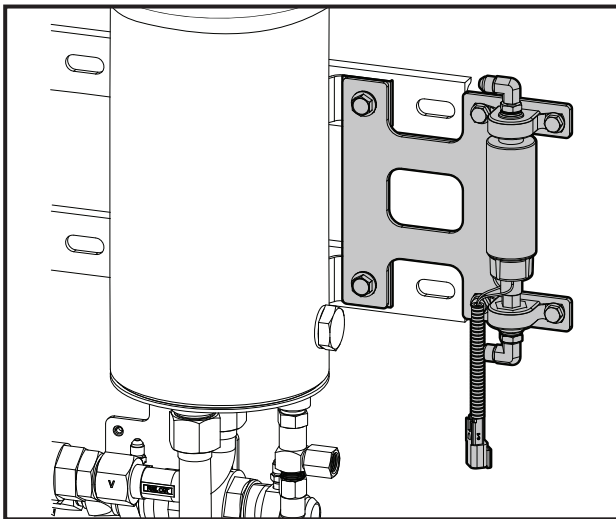

Figure 1 - Mounting the Primer Pump Assembly on the Bracket

⚠ CAUTION: Do not over tighten the mounting bracket bolts or fuel hoses to the fittings to avoid damaging the Primer Pump Assembly.

2. Remove straight fitting from the outlet manifold. See Figure 2.

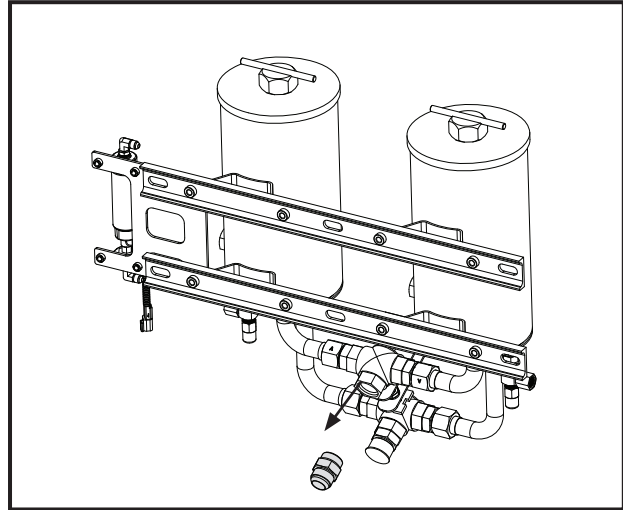

Figure 2 - Removing the straight fitting

3. Install the 90° fitting on the outlet manifold. See Figure 3

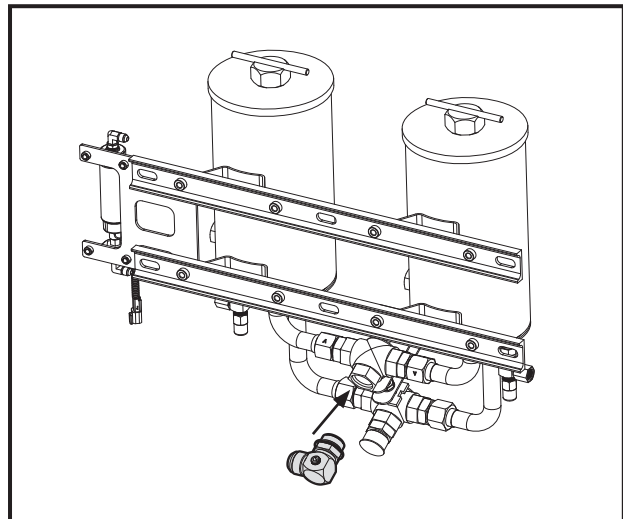

Figure 3 - Install the 90° fitting

4. Apply anti-seize paste to the threads of the Bypass Valve.

- Attach the Bypass valve to the fuel outlet fitting (on single units only) or the fuel outlet port (on units with manifolds) See Figure 4.

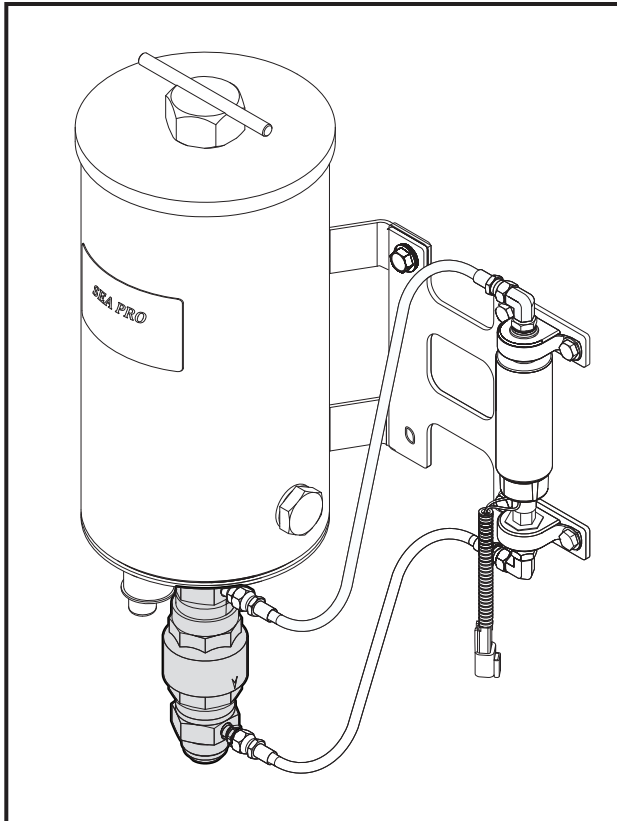

Figure 4 - Attaching the Bypass Single Unit

Note: The directional arrow on the Bypass Valve Must face away from the unit. See Figures 4 and 5.

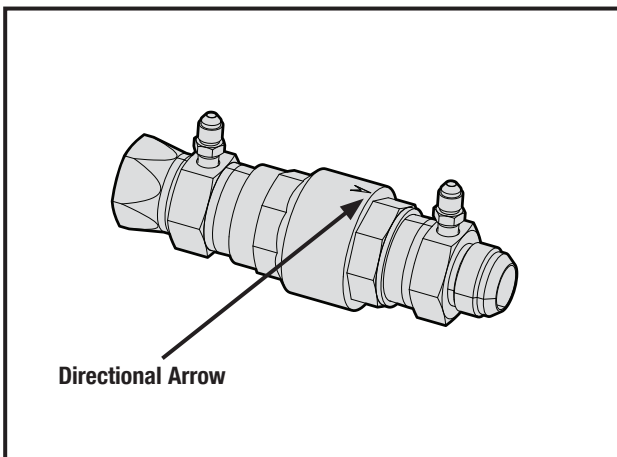

Figure 5 - Bypass Valve

- Torque the swivel fitting Bypass Valve to 115 ft-lb (193.0 N•m) for Single units (See Figure 4), or 50 ft-lb (67.8 N•m) for Duplex units. Rotate it to position. See Figure 6.

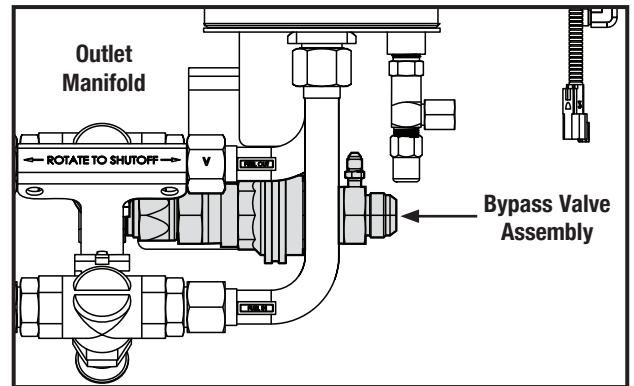

Figure 6 - Attaching the Bypass Valve (Duplex)

- Attach the Bypass Valve Bracket and strap as shown in Figure 7. Attach the Primer Pump Assembly outlet hose to the Bypass Valve at the end closest to the outlet manifold and attach the other end to the bottom of the Primer Pump as shown in Figure 7. Torque each fitting to 10-15 ft-lb (13.6-20.4 N•m).

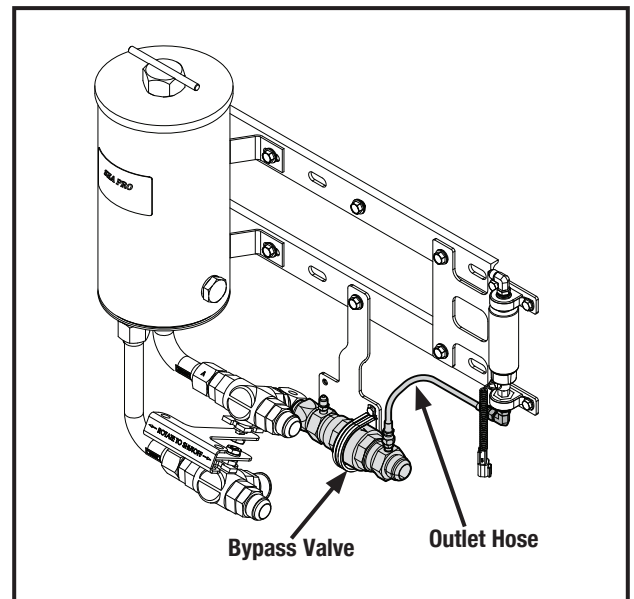

Figure 7 - Attaching the Outlet Hose

- Attach the Primer Pump Assembly inlet hose to the Bypass Valve at the end furthest from the outlet manifold and attach the other end.

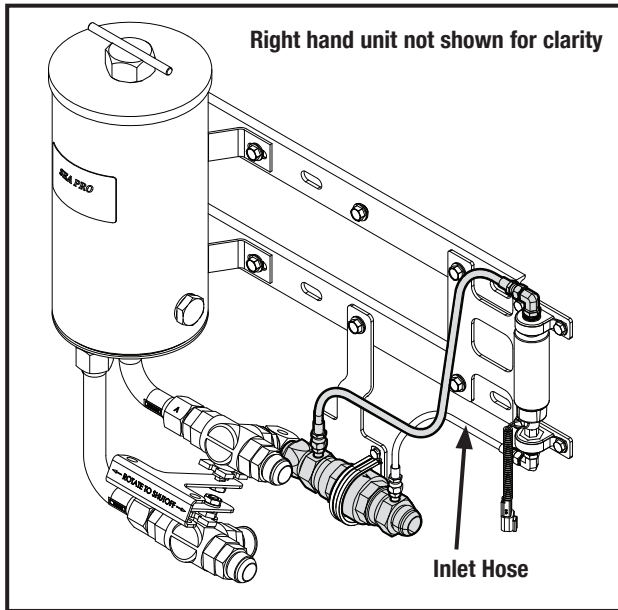

Figure 8 - Attaching the Inlet Hose

- Locate an electrical power source from the engine capable of providing 24 V, 6 A power to the Primer Pump. See Figures 9 and 10.

CAUTION: Use appropriate connectors to attach the wires to avoid damaging the Primer Pump. Add a 6 A fuse (not included).

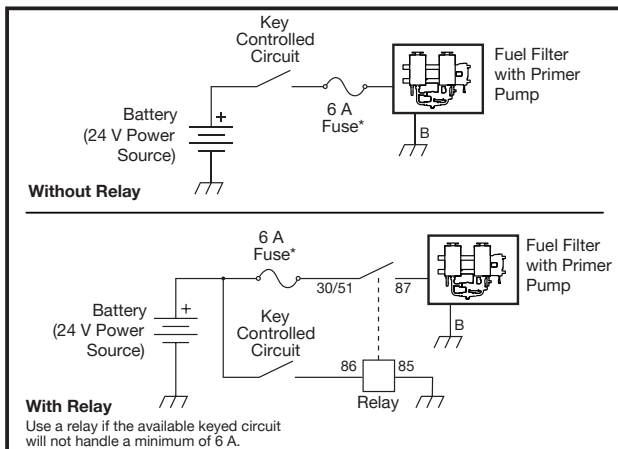

Figure 9 - Power Connection Schematics

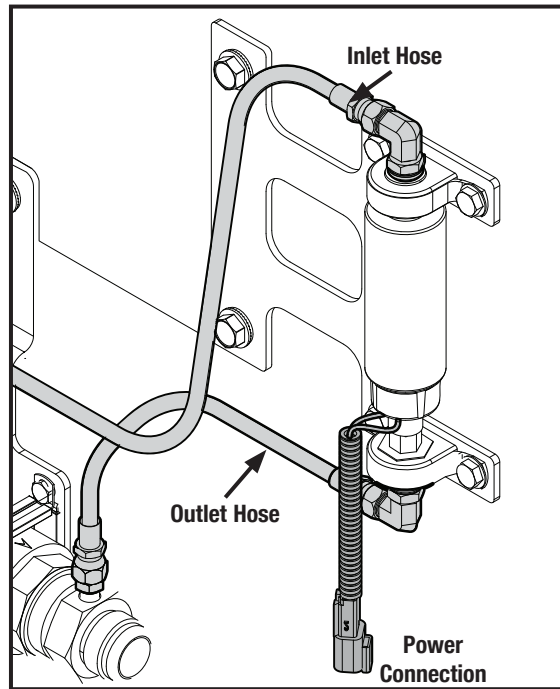

Figure 10 - Power Connection for Primer Pump

Suggested Preventive Maintenance

Every 12 Months - Check all electrical connections for corrosion. Check all fuel fittings for leaks.

Specification	Primer Pump
Supply Voltage	24V
Temperature Range	-20°F (29°C) to 250°F (120°C)

Specifications subject to change without notice.

Ordering Information

Primer Pump Kits

Description	Kit Part Number
Sea Pro Primer Pump Upgrade, Short Single	SP72243
Sea Pro Primer Pump Upgrade, Short Duplex	SP72245
Sea Pro Primer Pump Upgrade, Tall Single	SP72244
Sea Pro Primer Pump Upgrade, Tall Duplex	SP72246
Sea Pro Primer Pump Upgrade, Short Single w/o Pump	SP72365
Sea Pro Primer Pump Upgrade, Short Duplex w/o Pump	SP72366
Sea Pro Primer Pump Upgrade, Tall Single w/o Pump	SP72367
Sea Pro Primer Pump Upgrade, Tall Duplex w/o Pump	SP72368

Revision	Date	Description
A	04AUG2020	Released



Filtration

**For more information, visit
cumminsfiltration.com**

LT36675 - Rev A
©2020 Cummins Filtration Inc.
Printed in the U.S.A.