

Fuel Pro® Series Filter/Separator/Warmer Installation Instructions

Standard and Plus Series

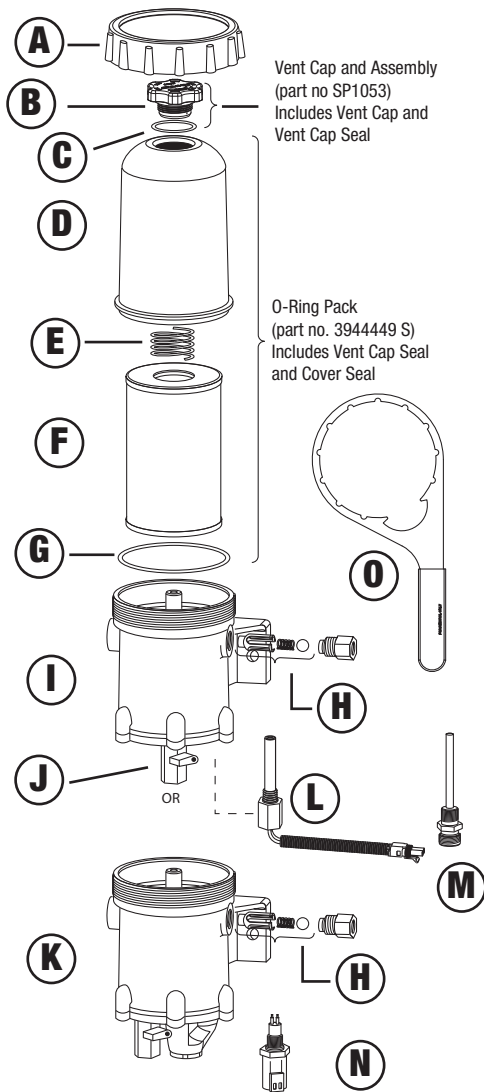

Part	Description	Part Number
A	Collar	3946706 S
B	Vent Cap	Vent Cap and Assembly SP1053
C	O-Ring	
D	Cover Assembly	SP1244
E	Holddown Spring	3944441 S
F	Filter Element (Includes Grommet and O-Rings)	See Ordering Information
G	O-Ring Pack - included with each replacement element	3944449 S
	Biodiesel Gasket Pack - only required for >B5 fuel	3950445 S
H	Check Valve Service Kit	3944447 S
I	Fuel Pro®, Unheated	See Ordering Information
J	Drain Valve	3944453 S
K	Fuel Pro, Heated	See Ordering Information
L	Pre-Heater, 12 V, 195 W, WP Connector	SP1321
	Pre-Heater, 24 VDC, 195 W, WP Connector	SP1319
M	120 VAC Electric Heater	See AC Heater Unit page
N	Water-In-Fuel (WIF) Sensor	3911940 S
	Water-In-Fuel (WIF) Sensor for Units with Fluid Heat	3977418 S
O	Collar Wrench, Composite	3944451 S
	Collar Wrench, Metal	3944448 S
Not Shown	WIF Wiring Harness	3950729 S
	WIF LED	3946670 S

Note: The WIF sensor is not included, but can be purchased separately.



CAUTION:

These instructions are intended for use by professional mechanics who are trained in the proper use of power and hand tools, using appropriate safety precautions (including eye protection).

EXT Series

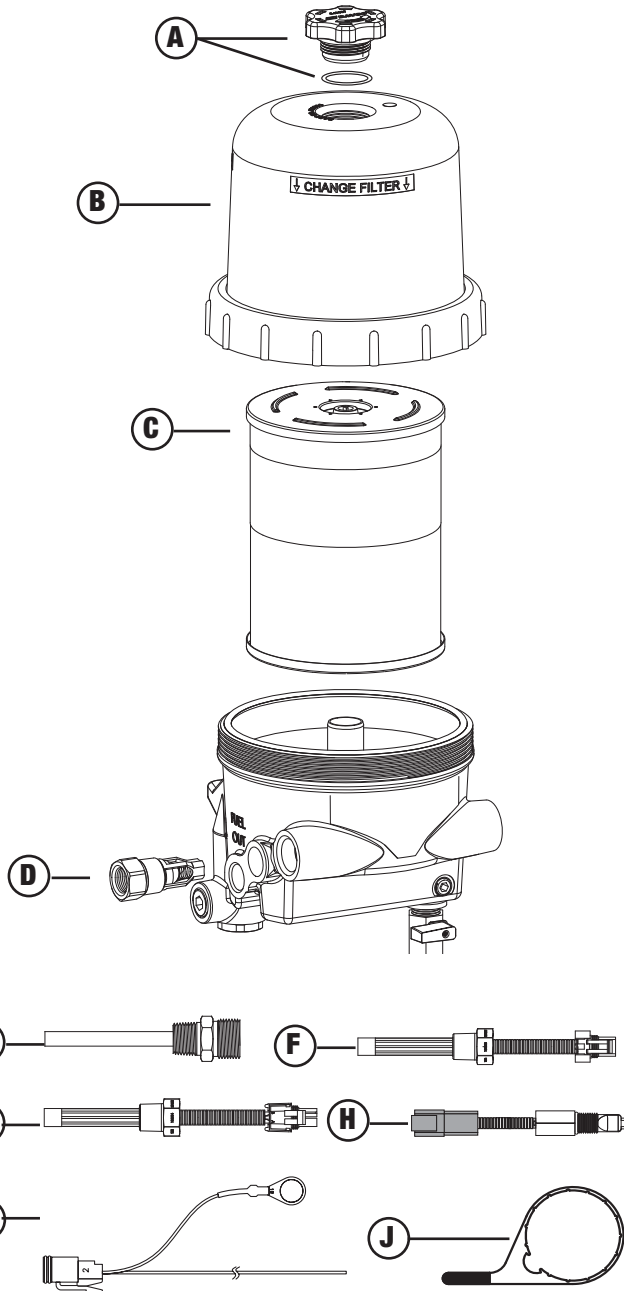

Part	Description	Part Number
A	Vent Cap & Seal	SP1053
B	Cover Assembly	SP1127
C	Filter Element	FS19915
D	Check Valve Assembly	3944454 S
E	120VAC Overnight Heater	3945121 S
F	12VDC Pre-Heater (Metri-Pack)	SP1320
G	12VDC Pre-Heater (Weather-Pack)	SP1322
H	WIF (Deutsch Connector)	3977418 S
I	WIF Wiring Harness	3950729 S
J	Metal Collar Wrench	SP1076

Note: The WIF sensor is not included, but can be purchased separately.

Service Kit Installation

This system must be installed between the fuel tank and the transfer fuel pump on the suction side of the fuel system. This system **can be used as the only fuel filter in the fuel system** by removing the existing filter and heads, or by removing the filters only and replace with special Diverter Caps (sold separately - See Table 1)

Note: If the Fuel Pro is used as the primary filter and a secondary filter is required, secondary filter life may be extended.

Table 1 - Diverter Cap Part Numbers

Diverter Cap Part Number	Required Filter Head Stud Size	Required Filter Head Seal ID	Required Filter Head Seal OD
3945182 S	1"-14	2.475"	2.895"
3945183 S	1"-14	3.225"	3.435"
3945184 S	M16 x 1.5	2.475"	2.895"
3945185 S	3/4" x 16	2.475"	2.895"
3945186 S	7/8 x 14	2.475"	2.895"
3945187 S	M18 x 1.5	2.475"	2.895"
3945188 S	13/16" x 12	3.225"	3.235"

WARNING: When diesel fuel is circulated through an operating engine, it can become very hot. To prevent personal injury:

- **Scalding hazard! Do not allow heated liquid fuel to come in contact with eyes or unprotected skin. Always allow the engine and fuel to cool to ambient temperature before replacing the fuel filter or performing service operations which could result in the spillage of fuel from the fuel system. If this is not possible, protective clothing (face shield, insulated hat, gloves, apron) must be worn.**
- **Heated diesel fuel can form combustible vapor mixtures in the area around the fuel source. To eliminate the potential for fire, keep open flames, sparks or other potential ignition sources away from the work area, and do not smoke during filter replacement or service operations which could result in the escape of diesel fuel or fuel vapors.**
- **Always perform engine or vehicle fuel system maintenance in a well ventilated area that is kept free of bystanders.**

Installing the Fuel Pro Service Kit

Step 1 - With the engine shut down and at ambient temperature, close the fuel shutoff valve (if equipped) and place a suitable container under the fuel filters.

Step 2 - Remove the primary fuel filter element assembly, sedimenter, and/or water separator. Drain the used element and dispose of it in an environmentally responsible manner, according to state and/or federal (EPA) or national recommendations. The fuel can be returned to the tank.

Step 3 - For a one-filter system, select the required secondary filter head diverter cap from those listed in Table 1. The required part number is determined by the size of the spin-on filter stud and the filter sealing surface diameter.

The Fuel Pro is designed to provide total engine filtration, when fitted with the appropriate filter to meet OEM engine specifications. Installation of the Fuel Pro should be on the suction side of the fuel system. Introducing the Fuel Processor to more than 30 psi (2.07 bar) at any time can cause unit failure or give false information regarding filter life.

Install the diverter cap on the secondary filter head as follows:

- Remove the secondary fuel filter element, drain and dispose of it in an environmentally responsible manner according to government regulations (i.e., state/province, federal, etc.). The fuel can be returned to the tank.
- Lightly lubricate the seal on the top of the diverter cap with clean engine oil.
- Thread the adapter onto the secondary filter stud and tighten by hand plus 1/2 turn further.
- Install the "Do Not Remove" sticker on the diverter cap.

Step 4 - Mount the Fuel Pro in the desired location keeping the following points in mind:

- Mounting the Fuel Pro directly on the engine is NOT RECOMMENDED.
- Mount vertically with the cover and element pointing up.
- Make sure there is enough top and side clearance for the cover to be conveniently removed for filter replacement.

CAUTION: The Fuel Pro functions BEST when installed so that the Filter Element is above the "FULL" level of the fuel tank. The housing can be installed up to 6' (1.8 m) below the "FULL" level of the fuel tank.

Installing below the “FULL” level causes the starting level to be higher than normal. If mounted below full tank level, a shut off valve will be required at the inlet to allow filter changes without overflow of fuel. Mounting below 6' (1.8 m) eliminates the Seeing is Believing functionality.

Step 5 - Route the fuel supply line from the fuel tank to the Fuel Pro inlet (Figure 1). Route a fuel line from the Fuel Pro outlet to the fuel pump inlet.

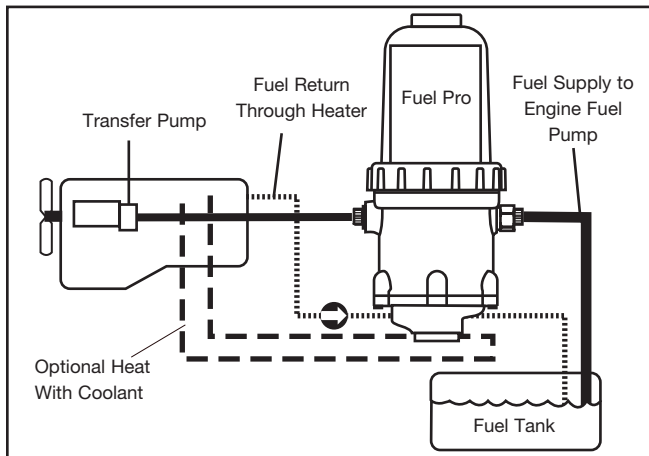

Figure 1 - Fuel Pro Connections

Step 6 - To minimize restrictions, observe the following guidelines when plumbing the system.

- a. Keep the fuel line routing as smooth as possible with no low hanging loops which can trap water.
- b. Use 90° elbows only when necessary.
- c. If the fuel hoses are made up to length on the job, be sure that the inner liner of the fuel hose is not cut by the fitting, creating potential check valve effects. Also make sure hoses are clean and free of debris before installing.

CAUTION: To avoid damaging the aluminum fuel processor body, do not overtighten fuel lines or fuel line fittings.

Installing a WIF (Water In Fuel) Probe

Step 1 - Install the WIF Probe (391194 S) into the bottom of the Diesel Pro (see Figure 2). Torque to 20-25 in-lbs (2.3-2.8 N-m).

Step 2 - Install the WIF wiring harness (3945151 S for Fuel Pro Standard and Plus, 3950729 S for EXT) on WIF Probe. The harness has the following connections: 12" (304.8 mm) black ground lead with a 3/8" (9.53 mm) diameter loop end and a 72" (1828.80 mm) green WIF wire.

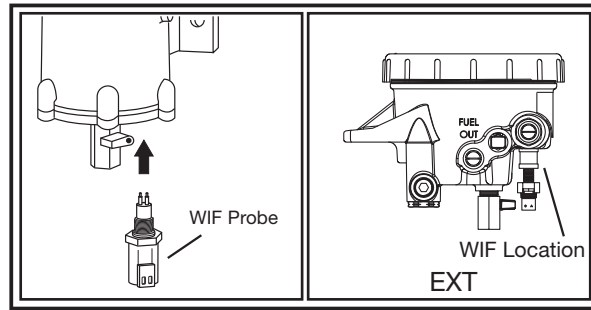

Figure 2 - WIF Probe Installation

Step 3 - Drill 1/2" (12.70 mm) hole in the dash or control panel where the WIF LED (3946670 S) is to be located.

- a. Installation must have 1.5" (38.10 mm) of clearance behind the dash or control panel.
- b. Use caution not to damage nearby components when drilling.

Step 4 - Install WIF LED by pressing firmly into the drilled hole.

Step 5 - Connect the 4" (101.60 mm) black ground wire on WIF LED to a ground source. Attach additional black wire as needed.

Step 6 - Connect the 12" (304.8 mm) black ground lead with a 3/8" (9.53 mm) diameter loop end on the WIF wiring harness to ground source near Fuel Processor (if applicable). See Figure 3.

Step 7 - Connect 72" (1828.80 mm) green signal wire on WIF wiring harness to 4" (101.60 mm) green signal wire on WIF LED. Use additional green wire as needed.

Step 8 - Locate 12 VDC or 24 VDC power source. Run red wire from power source to 4" (101.60 mm) red wire on WIF LED. Add a 10 A in-line fuse (not included).

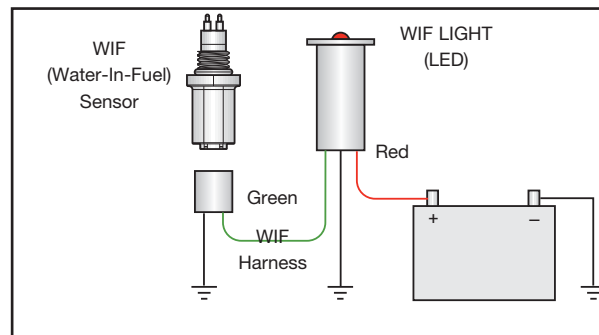

Figure 3 - WIF Wiring

Note: Use appropriate connectors to attach the wires. To test the WIF indicator, pour water into the body of the fuel processor until it covers the WIF probe. The WIF LED should illuminate. For unheated fluid, the volume of fluid necessary to turn the WIF indicator on is 6.15 oz \pm .07 oz (182 mL \pm 2 mL), for heated fluid the volume necessary is 3.08 oz \pm .07 oz (91 mL \pm 2 mL).

Fuel Heating Options

Note: The Engine Return Fuel Heat and Engine Coolant Heat options apply **ONLY** to the heater base shown in Figure 4. If the bottom plate is flat with 1/2" NPT ports, only the Electric Preheater can be used.

Engine Return Fuel Heat

Electronic unit injected engines can use return fuel as the fluid heat for the Fuel Pro. Route the return fuel line from the engine into the Heater Base of the Fuel Pro (see Figure 4). Either heater port will work as an inlet. Connect a second fuel return line from the Heater Base to the fuel tank return port.

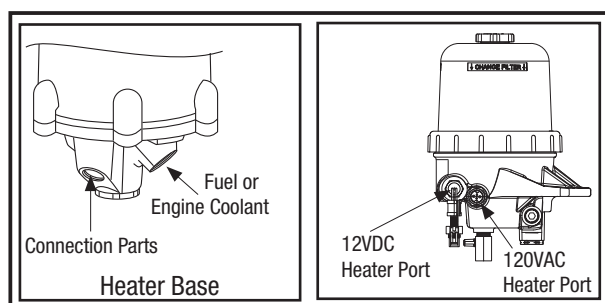

Figure 4 - Heater Base

Engine Coolant Heat

To use engine coolant as the Fuel Pro heating fluid, connect a hose (Braided #6 or #8 hose) from the high pressure side of the engine coolant system to the Fuel Pro Heater Base (see Figure 4). Either heater port will work as an inlet. Route another hose from the Heater Base to a low pressure port in the coolant system. **DO NOT route into the cab heater system.**

Electric Heater Upgrade Kits

This is a replacement kit for Fuel Pro® wire harness, thermostwitch, and pre-heater, to a pre-heater assembly. A replacement seal for the bottom plate and a pipe plug is included.

1. Drain all fuel from the Fuel Processor. Dispose of the fuel in an environmentally responsible manner.
2. Disconnect and remove the chassis harness, thermostwitch, and heater. (If necessary, remove the bottom plate from the unit for ease of assembly/disassembly).
3. Apply pipe sealant to threads of pipe plug and the new pre-heater and install into the bottom plate. If the bottom plate was removed, replace the seal (round style for bottom collar, square style for bolt-on) and reinstall. Torque bottom collar to 50-6- ft-lbs or screws to 10-12 ft-lbs.
4. Connect the pre-heater harness to the chassis power connector.
5. Start engine, when the lubrication system reaches normal operating pressure, increase the RPM for one minute. Slowly open vent cap until fuel level drops to one inch above collar. Hand tighten vent cap. See Table 2 for heater kits.

Table 2 - 12 V & 24 V Heater Units

Part Number	Description
SP1319	Pre-Heater, 24 V, 195 W, Weather-Pack Connector
SP1320	Pre-Heater, 12 VDC, 195 W, Metric-Pack Connector
SP1321	Pre-Heater, 12 V, 195 W, Weather-Pack Connector
SP1322	Pre-Heater, 12 V, 195 W, Weather-Pack Connector
3945121 S	120 VAC, 75 W Overnight Heater

Note: 25 A fuse is recommended but not included in Fuel Pro kits

Table 3 - 120 V Heater Unit

Heater	3945121 S		
Description	120 VAC		
Product	Fuel Pro		
Connector	Part Number	3945126 S	3946716 S
	Type	Single Cordset	Y Cordset (Y cord to processor and block heater w/ locking ring)
	Plug	120 V Male Wall Plug	120 V Male Wall Plug
	Temp. Rating	221° F (105° C)	221° F (105° C)
	Cordset Length	72" (182.9 cm)	Straight Leg - 84" (213.3 cm) Long Leg - 120" 304.8 cm)

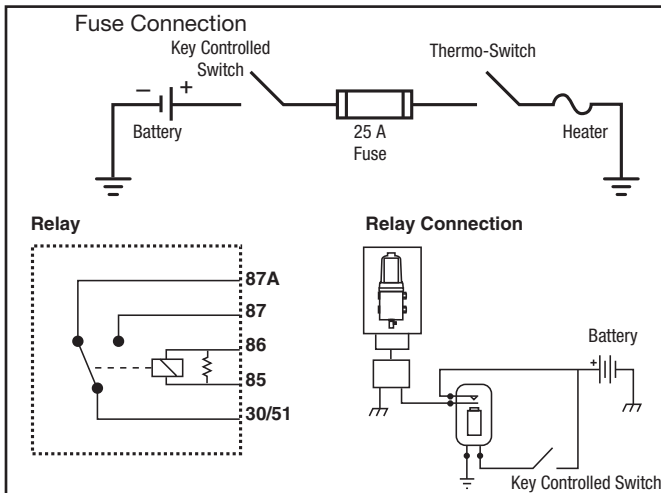

Figure 5 - Fuse and Relay Connects

Two types of cordsets are available for the 120 V heater. See Table 3 and Figure 6 for cordset information.

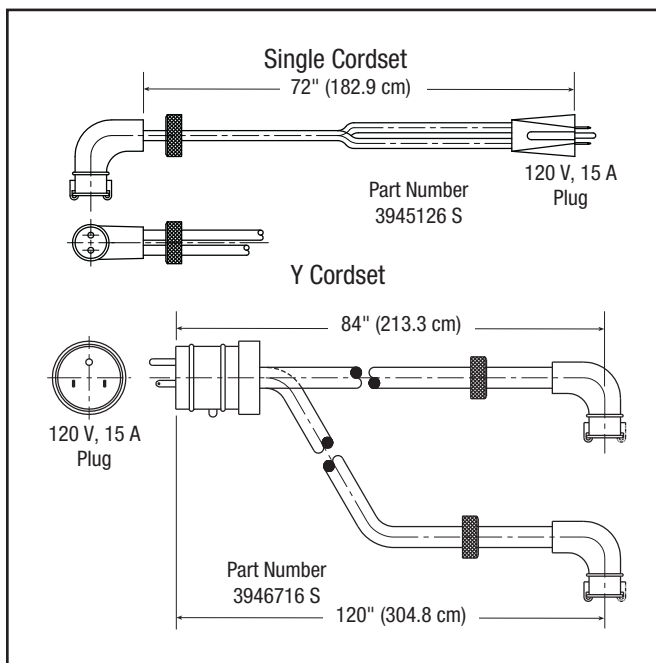

Figure 6 - Electric Heater Cordsets

Filter Change Procedure

Step 1 - Turn off the engine. Loosen the vent cap to break the air lock in the filter.

Step 2 - Open the drain valve and drain the fuel level below the collar, then close the drain valve. Dispose fuel and filter in an environmentally safe manner, according to state and/or federal (EPA) recommendations.

Step 3 - Using the Collar Wrench (part number 3944451 S (composite) Figure 7, 3944448 S (metal) Figure 8, or SP1076 for EXT series), remove the clear cover from the fuel processor by removing the collar. Discard the o-ring from the base of the cover. (A new o-ring seal is supplied with the new filter.) For Biodiesel applications use gasket pack 3950445 S. Gasket color is green and **MUST** be changed with every filter change. Remove the filter element from the Fuel Pro by pulling upward and twisting slightly. Be sure the sealing grommet is removed from the center stud.

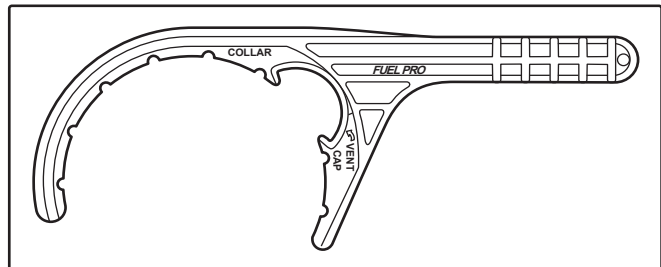

Figure 7 - Composite Collar Wrench

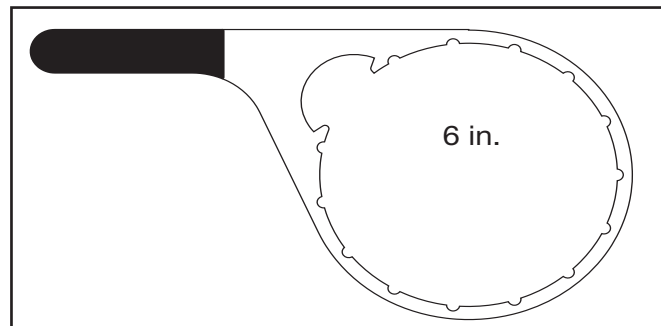

Figure 8 - Metal Collar Wrench

Step 4 - Install a new filter, cover seal and vent cap seal. Reinstall the clear cover and collar. Simultaneously apply downward pressure to top of the clear cover until it is seated on the body of the Fuel Pro and hand tighten the collar until it no longer spins freely. Torque the cover assembly by rotating the collar clockwise (~18 ft-lbs)

Step 5 - Remove the vent cap from the top of the clear cover by turning the vent cap counterclockwise. Fill the clear cover with enough clean fluid to cover the bottom half of the filter element. Make sure the new o-ring (supplied with the filter) is installed on the vent cap. Reinstall the vent cap and **tighten by hand only**.

Step 6 - Start the engine. When the lubrication system reaches its normal operating pressure, increase the engine RPM for one minute.

Table 4 - Replacement Filters

Part Number	Description
FS19761	EleMax™ Stratapore™ 5 micron
FS19624	EleMax™ Stratapore™ 7 micron
FS19727	EleMax™ Stratapore™ 10 micron
FS19728	EleMax™ Stratapore™ 25 micron
FS19729	EleMax™ Cellulose 50 micron
FS19763	EleMax™ Stratapore™ 7 micron (plus size)
FS19764	EleMax™ Stratapore™ 10 micron (plus size)
FS19765	EleMax™ Stratapore™ 25 micron (plus size)
FS19766	EleMax™ Stratapore™ 5 micron (plus size)
FS19905G	EleMax™ Stratapore™ 50 micron (plus size)
FS19915	EleMax™ Stratapore™ 7 micron (ext size)

Note: The clear filter cover will not fill completely during engine operation. It will gradually fill over time as the filter becomes clogged. The filter element does not need to be changed until the fuel level has risen to the top of the filter element.

Priming the System

Step 1 - Check to make sure the drain valve at the base of the Fuel Pro is closed.

Step 2 - Remove the vent cap from the top of the clear cover. Fill the Fuel Pro full of clean fuel. Reinstall the vent cap and **tighten by hand only**.

Step 3 - Start the engine. When the lubrication system reaches it's normal operation pressure, increase engine speed to high idle for one to two minutes. After the air is purged, loosen the vent cap until the fuel level lowers to just above the bottom of the collar. **Tighten the vent cap by hand only.**

Note: The clear filter cover will not fill completely during engine operation. It will gradually fill over time as the filter becomes clogged.

Step 4 - Hand tighten the collar again while the engine is running. **To avoid damage, do not use tools to tighten the collar.**

Emergency Temporary Filter Replacement

Step 1 - Follow steps 1 through 3 of the "Filter Change Procedure" on page 5.

Step 2 - If there is a filter grommet on the filter stud, remove it.

Step 3 - Install an engine spin-on filter (part number FF105, for example) on the threaded stud.

Step 4 - Install the cover, spring, seal and collar over the filter for later reuse and to guard against loss.

Step 5 - Start the engine. Raise the RPM for one minute to purge the air from the system.

Draining Contaminants

Step 1 - Turn off the engine and open the filter vent.

Step 2 - Place a cup under the drain valve at the base of the Fuel Pro and open the drain valve.

Step 3 - Water will flow into the cup. When Fuel begins to flow out of the drain, close the drain valve. (Drain the minimum amount of fuel possible.)

Step 4 - Close the filter vent.

Step 5 - Start the engine. Raise the RPM's for one minute to purge the air from the system.

Suggested Preventive Maintenance

Weekly - Drain water.

Every Filter Change - Change o-rings and grommet (included with new filter).

Every 12 Months - Check all electrical connections for corrosion. Check all fuel fitting for leaks.

Extreme winter or salt corrosion environments may require lubrication of the top collar threads with Loctite® 76747 antiseize every 180 days.

Ordering Information

Housing Part Number	Filter Element**	Size	Pre-Heater 1	Pre-Heater 2	Fluid Heat	WIF	Fuel Flow
FH23027	FS19763	Plus	12 VDC	120 VAC	Yes	No	In Right / Out Left
FH23028	FS19763	Plus	24 VDC	120 VAC	Yes	No	In Right / Out Left
FH23029	FS19763	Plus	N/A	N/A	N/A	No	In Right / Out Left
FH23030	FS19905G	Plus	N/A	N/A	N/A	No	In Right / Out Left
FH23031	FS19763	Plus	12 VDC	N/A	N/A	No	In Right / Out Left
FH23032	FS19763	Plus	24 VDC	N/A	N/A	No	In Right / Out Left
FH23038	FS19763	Plus	N/A	N/A	Yes	No	In Right / Out Left
FH23039	FS19763	Plus	N/A	N/A	Yes	Yes	In Right / Out Left
FH23040	FS19763	Plus	12 VDC	N/A	Yes	No	In Right / Out Left
FH23041	FS19763	Plus	12 VDC	N/A	Yes	Yes	In Right / Out Left
FH23042	FS19763	Plus	24 VDC	N/A	Yes	No	In Right / Out Left
FH23045	FS19763	Plus	120 VAC	N/A	Yes	No	In Right / Out Left
FH23048	FS19728	Plus	24 VDC	120 VAC	N/A	Yes	In Right / Out Left
FH23049	FS19763	Plus	12 VDC	N/A	N/A	Yes	In Right / Out Left
FH23050	FS19763	Plus	24 VDC	N/A	N/A	Yes	In Right / Out Left
FH23054	FS19763	Plus	12 VDC	120 VAC	N/A	No	In Right / Out Left
FH23060	FS19765	Plus	N/A	N/A	N/A	Yes	In Right / Out Left
FH23061	FS19763	Plus	N/A	N/A	N/A	Yes	In Right / Out Left
FH23067 M*	FS19765	Plus	24 VDC	N/A	N/A	Yes	In Right / Out Left
FH23068 M*	FS19765	Plus	Ports Available	N/A	N/A	Yes	In Right / Out Left
FH23069 M*	FS19765	Plus	24 VDC	N/A	Yes	Yes	In Right / Out Left
FH23076	FS19763	Plus	N/A	N/A	N/A	No	In Right / Out Left
FH23100	FS19915	EXT	N/A	N/A	N/A	No	In Left / Out Left
FH23127	FS19764	Plus	12 VDC	N/A	N/A	Yes	In Right / Out Left
FH23128	FS19765	Plus	12 VDC	N/A	N/A	Yes	In Right / Out Left
FH23129	FS19905G	Plus	N/A	N/A	N/A	Yes	In Right / Out Left
FH23130	FS19764	Plus	N/A	N/A	N/A	Yes	In Right / Out Left
FH23131 M*	FS19764	Plus	Ports Available	N/A	N/A	Yes	In Right / Out Left
FH23132 M*	FS19763	Plus	24 VDC	N/A	N/A	Yes	In Right / Out Left
FH23166	FS19915	EXT	24 VDC	N/A	N/A	Yes	In Right / Out Left

* M designates metric connections of M22 x 1.5.

** Bio Oil Fuel Pro. Accept only Plus Size replacement Filters

***For Biofuels above B5, the following gasket pack must be used to replace the standard gaskets that are provided with the filter element 3950445 S

Dimensions

Standard and Plus Series

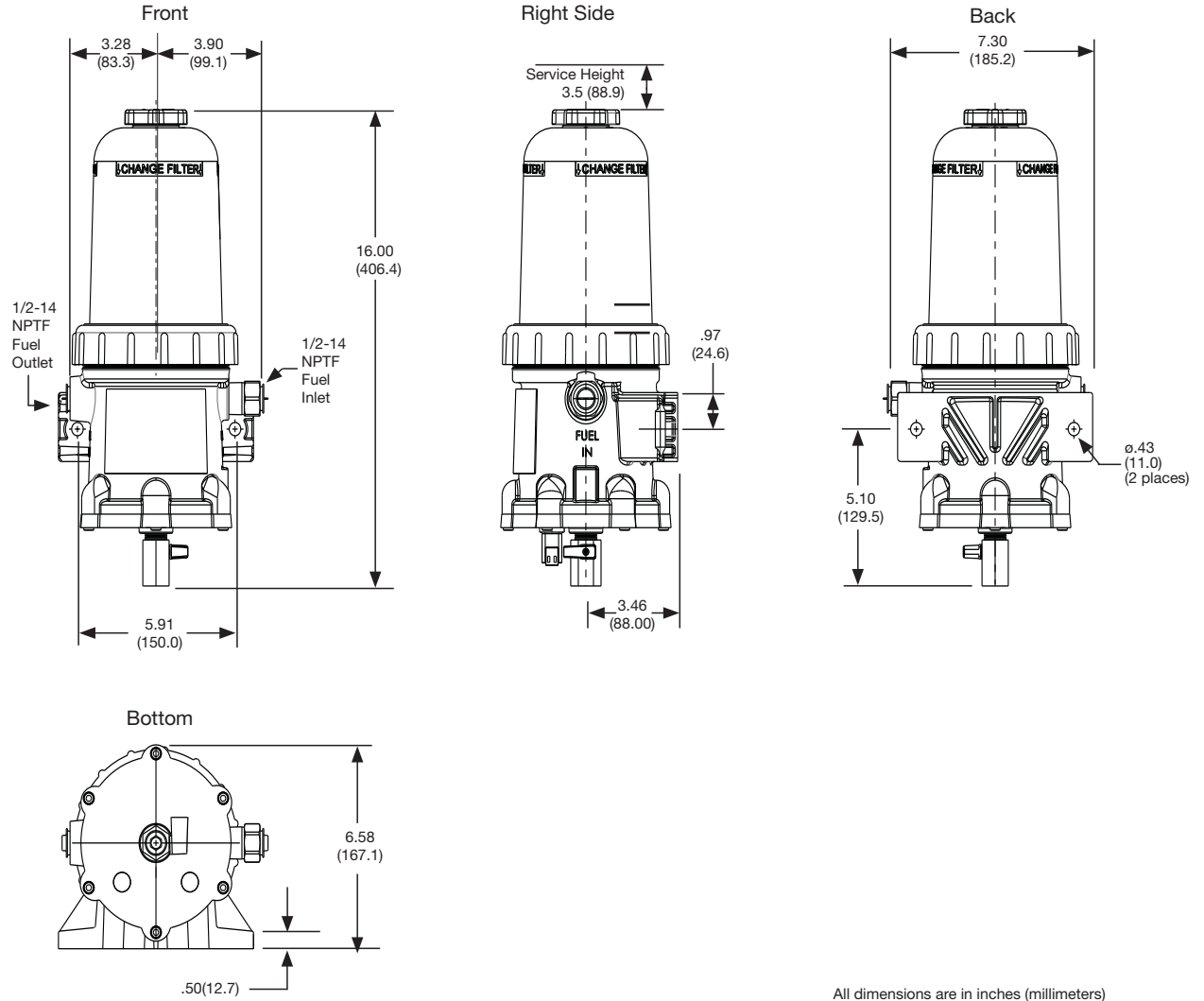

All dimensions are in inches (millimeters)

EXT Series

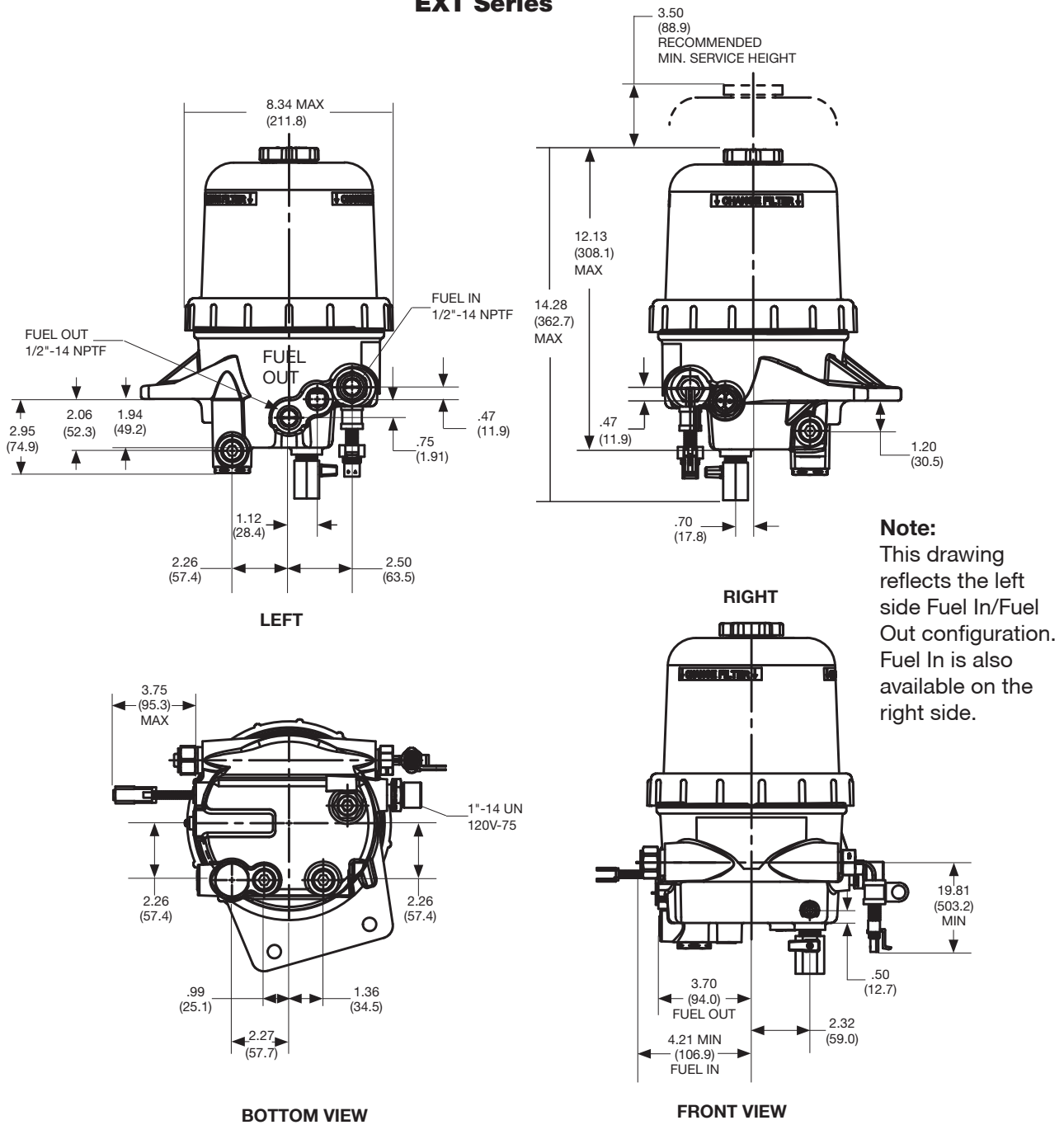

All dimensions are in Inches (millimeters)

Specifications

Specifications	Standard and Plus	EXT
Overall Height	16.13"	14.28" (362.7 mm)
Overall Depth	7.25"	6.58" (167.13 mm)
Maximum Width	6.89"	8.35" (211.8 mm)
Mount Bracket Centers	5.91"	3.94" (100.0 mm)
Dry Weight	7.25 - 9.75 lbs	10.35 lbs
Fuel In Connection	1/2"-14 NPTF (M22 x 1.5)	1/2"-14 NPTF (M22 x 1.5)
Fuel Out Connection	1/2"-14 NPTF (M22 x 1.5)	1/2"-14 NPTF (M22 x 1.5)
Fluid Heat Connection (Inlet)	3/8"-18 NPTF (M14 x 1.5)	1/2"-14 NPTF (M22 x 1.5)
Fluid Heat Connection (Outlet)	3/8"-18 NPTF (M14 x 1.5)	1/2"-14 NPTF (M22 x 1.5)
Fuel Capacity (w/filter)	64.2 fl oz (1.9 L)	110.2 fl oz (3260 ml)
Recommended Applications	Heavy Duty Engines	
Water Trap Capacity	33.8 fl oz (1.0 L)	20.29 fl oz (600 ml)
Filter Service Clearance	Min 1.5" (38.1 mm)	Min. 3.50" (88.9 mm)
Operation Fuel Flow Rate	180 gal/hr (681 L/hr)	180 gal/hr (681 L/hr)
Electric Pre-heater	12 VDC, 195 W, 8.5 A +/-0.8	12 VDC, 195 W, 8.5 A +/-0.8
	24 VAC, 195 W, 4.5 A +/-0.4	24 VAC, 195 W, 4.5 A +/-0.4
	120 VDC, 75 W, 0.63 A ± 0.1	120 VAC, 75 W, 0.63 +/-0.1
Fuel Types	Compatible for use with #1 Diesel, #2 Diesel, Kerosene, Biodiesel, and JPS	

Performance

Standard and Plus Series

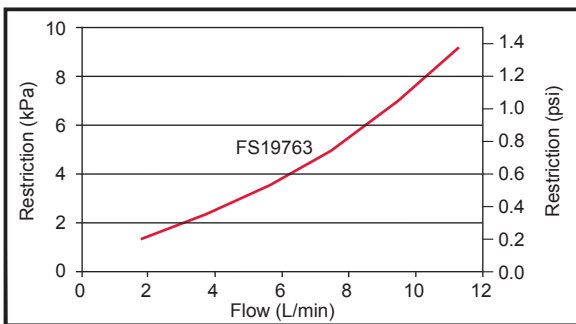

EXT Series

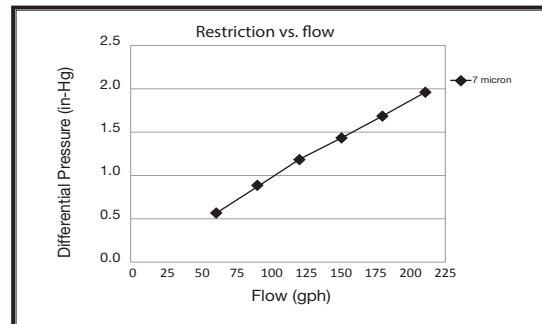

Revisions

Revision	Date	Description
9	10/18/2017	Added "Standard, Plus, and XLT" series to differentiate between product sizes. Renamed Instructions to Fuel Pro Series from FH23 Series.
10	12/04/2017	Updated Vent Cap - SP1053 was 3944440 S, SP1321 was 3959753 S, SP1319 was 3952119 S, Diverter Cap 3945185 S was 3945485 S, Electric Heater Upgrade Kits was Optional Preheater steps, Revised heater information in Table 2, Composite Collar Wrench was Collar/Vent Cap Wrench, Added Metal Collar Wrench - Figure 8, Revised Step 4 in the Filter Change Procedure, Revised descriptions on replacement filters FS19761 and FS19766 to 5 micron from 2 micron. Removed duplicate Caution note. Revised graphics for the Dimension Standard and Plus to show current vent cap. Added FH23048 and removed FH23082M and FH23072GM in ordering information.
11	01/18/2018	FH23030 filter element FS19905G Plus was FS19729 Standard, FS19905G was FS19729, EXT was XLT in all instances



Filtration For more information, visit cumminsfiltration.com

LT32582 Rev. 11
©2017 Cummins Filtration Inc.
Printed in the U.S.A.